

Platinum Split **TECH MANUAL**

**FOR SYSTEMS EQUIPPED WITH:
WATER COOLED CONDENSING UNIT**

*Whisper***KOOL**[™]
The Coolest Thing In Wine Storage

We manufacture, test and certify 100% of our wine cooling units in the USA. By sourcing the best components and closely controlling our manufacturing processes, we can assure the highest-quality, lowest defect manufacturing rates in the industry.

Copyright © 2012. WhisperKOOL. All rights reserved.

This manual, the product design, and the design concepts are copyrighted by WhisperKOOL, with all rights reserved. Your rights with regard to the hardware and manual are subject to the restrictions and limitations imposed by the copyright laws of the United States of America. Under copyright laws, this manual may not be copied, reproduced, translated, transmitted, or reduced to any printed or electronic medium or to any machine-readable form, for any purpose, in whole or in part, without the written consent of WhisperKOOL.

Every effort has been made to ensure that the information in this manual is accurate. WhisperKOOL is not responsible for printing or clerical errors.

WhisperKOOL reserves the right to make corrections or improvements to the information provided and to the related hardware at any time, without notice.

Vinothèque and WhisperKOOL are registered trademarks, and ECE is a trademark of WhisperKOOL. All rights reserved.

Mention of third-party products is for informational purposes only and constitutes neither an endorsement nor a recommendation. WhisperKOOL assumes no liability with regard to the performance or use of these products.

TABLE OF CONTENTS

Quick Reference Guide (Q.R.G)	
Controller Layout & Wall Mount Specifications	2
Ducted Platinum Split Specifications	3
Receiving & Inspecting The System	4
Before You Start	5
Preparing the Wine Cellar	6
Preparing the Evaporator Unit (Fan Coil Unit)	9
Installing the Evaporator Unit (Fan Coil Unit)	12
Drain Line	14
Evaporator Unit (Fan Coil Unit) Wiring Schematic	15
Preparing The Condensing Unit	16
Quick Reference Guide Water Cooled Condensing Unit ...	17
Line Set Piping Diagrams	18
Installing the Condensing Unit	19
Q.R.G Wall Mount Kit Option (Installed)	23
Installing the Wall Mount Kit	24
Fully Ducted Installation Information	26
Q.R.G Ducted Configuration Option (Installed)	27
Installing the Fully Ducted Accessory Kit	28
Remote Keypad Installation	29
System Operation	30
Remote Controller Functions	31
Troubleshooting Guide	34
Technical Assistance & Accessories	36

WhisperKOOL requires that a **certified HVAC-R technician** install, Pipe, Evacuate, Charge, Start and Test all split systems. A Nate Certification is recommended. Please take a moment to review state and city building codes to ensure the safe and proper installation of the system.
Read, understand and comply with the unit's installation manual, and piping diagrams.

QUICK REFERENCE GUIDE

Controller Layout

Refer to page 31 for complete listing of buttons and symbols.

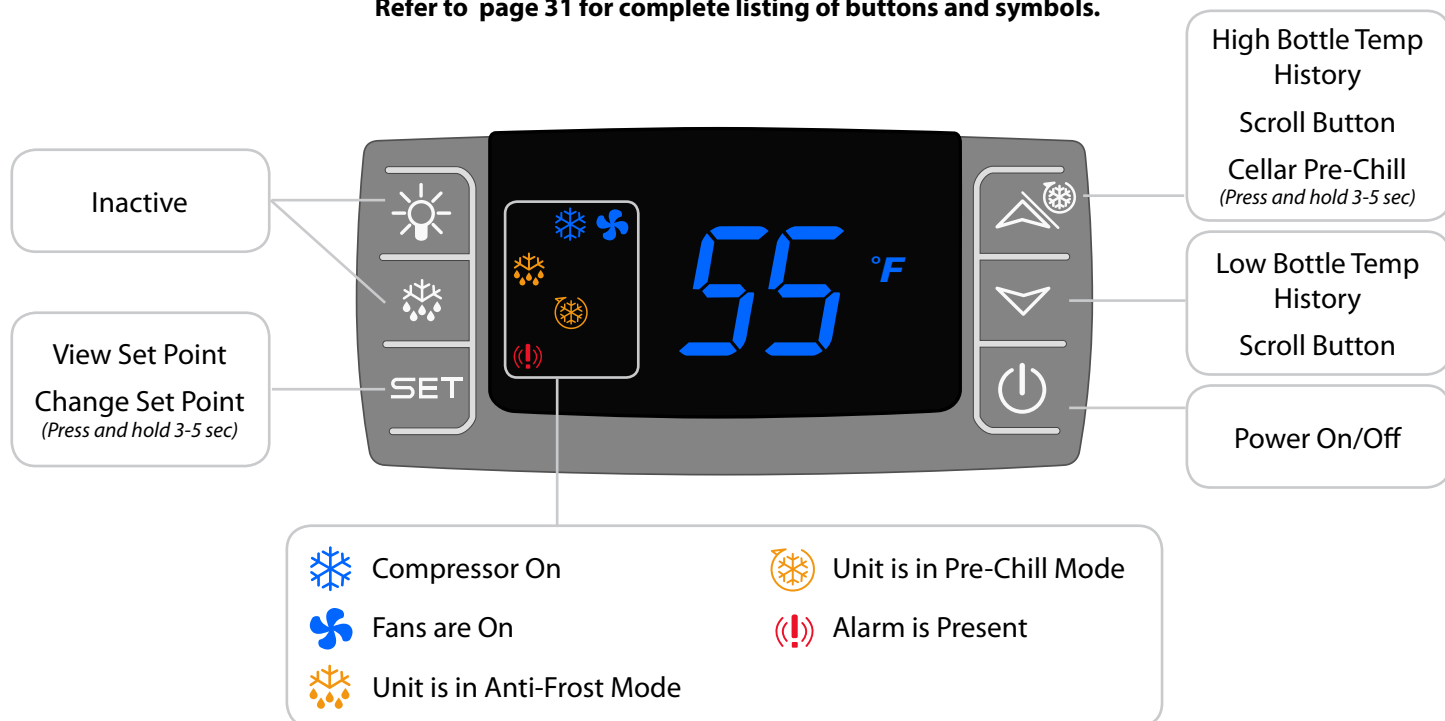

WALL MOUNTED PLATINUM SPLIT UNIT SPECIFICATIONS

Model	4000 Evaporator (Fan Coil Unit)	4000 Condenser (Water Cooled Condensing Unit)
Cellar Size (cu. ft.)	1000	
Dimensions	20.5"w x 15.5"h x 14.5"d	13"w x 10"h x 18.5"d
BTUh with 90° air entering the Condenser Coil	3650	
CFM	270	N/A
Refrigerant	R-134a	
Condensing Unit HP	1/3++	
Voltage Rating (20 amp dedicated circuit required)	115V	
Weight (lbs)	56	44
AMPS (Starting/Running)	2/1	32.7/7.2
dBA	54	50
Drainline	1/2" Condensate	
Installation	Evaporator Unit (Fan Coil Unit) is installed in the cellar or up to 25 ducted ft. away, condenser is installed up to 100 ft	
Thermostat	Digital Control Display	
Temp. Delta	55°F Temperature differential between the cellar temperature and condenser air intake temperature.	
Warranty	2 year parts and labor	

DUCTED PLATINUM SPLIT UNIT SPECIFICATIONS

Model	4000 Evaporator (Fan Coil Unit)	4000 Condenser (Water Cooled Condensing Unit)
Cellar Size (cu. ft.)	1000	
Dimensions	23.75"w x 15"h x 22.5"d	13"w x 10"h x 18.5"d
BTUh with 90° air entering the Condenser Coil	3120	
CFM	200	N/A
Refrigerant	R-134a	
HP	1/3++	
Voltage Rating (20 amp dedicated circuit required)	115V	
Weight (lbs)	57	44
AMPS (Starting/Running)	2/1	32.7/7.2
dBa	54	50
Drainline	1/2" Condensate	
Installation	Use 8" insulated ducting. Ducting should not exceed 25 ft. from the cellar.	
Thermostat	Optional Digital Remote Display	
Temp. Delta	55°F Temperature differential between the cellar temperature and condenser intake air temperature.	
Warranty	2 year parts and labor	

RECEIVING & INSPECTING THE SYSTEM

Receiving and Inspecting the System

- Lift only at the designated hand hold locations on the shipping container or fully support the unit from underneath. A shipment may include one or more boxes containing accessories.
- Before opening the container, inspect the packaging for any obvious signs of damage or mishandling.
- Write any discrepancy or visual damage on the Bill of Lading before signing.
- Allow the condensing unit to sit for 24 hours prior to start up. The condensing unit can be placed in the installation location piped and evacuated during this time.

Note: WhisperKOOL units are manufactured in the USA and tested prior to shipment.

Review the Packing Slip to Verify Contents

- Check the model number to ensure it is correct.
- Check that all factory options ordered are listed.

If any items listed on the packing slip do not match your order information, contact WhisperKOOL Customer Service immediately.

Check the Box for the following contents:

Main Evaporator Box

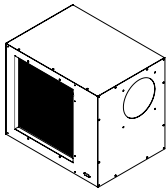

(1) Platinum Split Evaporator Unit
(Fan Coil Unit) Unit

- (1) Installation Kit which includes:
- | | |
|--|--------------------------|
| (7) #14 2" Phillips Pan Head Screw | (1) 1/4" copper coupling |
| (1) 1/2" Drain Tube Connector | (1) 3/8" copper coupling |
| (1) 10 ft. 1/2" Drain Line | (1) 1/4" sight glass |
| (1) 10 1/2" piece of 1/4" od copper tubing | (1) 1/4" filter drier |
| (1) 10 1/2" piece of 3/8" od copper tubing | (1) 13' Power Cord |

Main Condensing Unit Box



(1) Water Cooled
Condensing Unit

Wall-Mount Accessory Kit

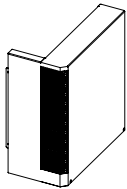

(1) Side Grille

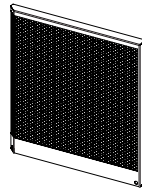

(1) Filter Grille

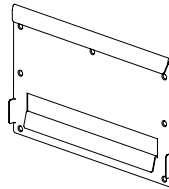

(1) Mounting Bracket

- (1) Split System Warranty Checklist
- (1) Platinum Split Owners Manual
- (1) Warranty Registration Card
- (1) 12 ft. Bottle Probe
- (10) 6-32 3/8" Phillips Pan Head Screw
- (1) Black Strain Relief

Ducted Accessory Kit

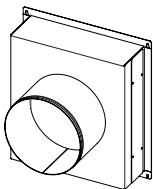

(1) 8" Return Air Plenum

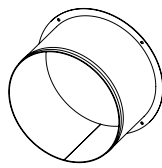

(1) Supply Air Collar

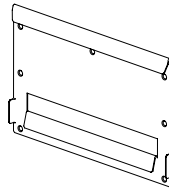

(1) Mounting Bracket

- (1) Split System Warranty Checklist
- (1) Platinum Split Owners Manual
- (1) Warranty Registration Card
- (1) 50 ft. Bottle Probe
- (1) Remote Keypad
- (1) 50 ft. Keypad Communication Cable
- (2) Black Strain Relief
- (10) 6-32 3/8" Phillips Pan Head Screw

Please leave the unit in its original box until you are ready for installation. This will allow you to move the product safely without damaging it. When you are ready to remove the product from the box, refer to the installation instructions.

TIP: Save your box and all packaging materials. They provide the only safe means of transporting/shipping the unit.

BEFORE YOU START

1. **Inspect all components prior to installation.** If damage is found, please contact your distributor or WhisperKOOL Customer Service at 1.800.343.9463.
2. The condensing unit **requires a dedicated 115-volt 20-amp circuit.** Use a surge protector with the unit. **Do not use a GFI** (Ground Fault Interrupter) line.
3. It is **REQUIRED** to **install a drain line** to remove condensation from the Evaporator Unit (Fan Coil Unit).
4. The system is intended **for use in properly designed and constructed wine cellars.** Hire a professional wine storage consultant with a valid contractor's license to build your wine cellar.
5. WhisperKOOL requires that all Split Systems are installed by a certified HVAC-R technician. A Nate certified technician is recommended.
6. Warranty is not active until a Warranty Checklist has been received, reviewed, and approved.

If you encounter a problem with your WhisperKOOL system, please refer to the Troubleshooting Guide on page 36. If you have any further questions, concerns, or need assistance, please contact WhisperKOOL's Customer Service at 1.800.343.9463. Please be sure all testing has been completed prior to contacting Customer Service. Please have your results ready for your representative.

PREPARING THE WINE CELLAR

The performance and life of your system is contingent upon the steps you take in preparing the wine cellar.

Note: Improperly preparing your enclosure or incorrectly installing your unit may cause unit failure, leaking of condensation, and other negative side effects.

IT IS HIGHLY RECOMMENDED THAT YOU OBTAIN THE ASSISTANCE OF A WINE STORAGE PROFESSIONAL.

Wine storage professionals work with licensed contractors, refrigeration technicians, and racking companies to build well-insulated, beautiful, and protective wine cellars. WhisperKOOL has put together some useful tips to assist in the installation process. Our recommendations are meant to act as a guide in the process of building a proper enclosure. Your intended location may have specific needs that we do not address.

Wall & Ceiling Framing

Build wine cellar walls using standard 2x4 or 2x6 construction methods and ceiling joists following the guidelines of local and state codes in your area. As a general rule, the thicker the walls and the higher the insulation value in your cellar, the better it will be at maintaining a consistent temperature.

Insulation

Insulation is **REQUIRED** with the use of the WhisperKOOL product. Standard fiberglass or rigid foam insulation is normally used in cellar construction or, in some cases, "blown-in" insulation is used. It is very important that all walls and ceilings are insulated to keep the cellar temperature as consistent as possible during the summer and winter months. The R-value, or quality of insulation, is determined by the rate at which heat passes through the insulation. The higher the R-value, the more resistant the insulation is to conducting heat. Using higher R-values in insulation will lower your operating costs and unit run time. (R-13 minimum, R-19 recommended, R-30 for ceiling and exterior walls.)

Vapor Barrier

Water vapor creates its own pressure, separate from the air pressure, and will intrude into colder/drier areas. A vapor barrier is **REQUIRED** to prevent the intrusion of water vapor so that the cellar can be kept at the correct temperature and humidity. 6 mm plastic sheeting (recommended) should be applied to the warm side of the cellar walls. The vapor barrier must also be applied to the outside walls and ceiling. If it is impossible to reach the outside, then the plastic must be applied from within the cellar. The most common method is to wrap the entire interior, leaving the plastic loose in the stud cavity so the insulation can be placed between each stud. All of the walls and ceiling must be wrapped in plastic for a complete vapor barrier.

In areas of high humidity, such as Southern and Gulf States, the vapor barrier will prevent infiltration of warm moist air. The moist air can cause mold to form, and standing water in drain pans promote microbial and fungal growth that cause unpleasant odors and indoor air quality problems. If mold is found, remove it immediately and sanitize that portion of the unit. Note: High humidity significantly increases the heat load on the cooling system.

Any break in the vapor barriers (cut, nail hole, over-lapping, etc) will allow a moisture leak and must be sealed. Electric conduit is a "duct" for vapor to travel in. The conduit should be caulked and sealed on the warm air end.



Unobstructed Airflow

Unobstructed airflow to and from the Evaporator Unit (Fan Coil Unit) is critical for the system's overall performance and life-span. A minimum three-foot clearance (five foot is ideal) area is crucial. The air the fans blow needs to circulate and either dissipate or absorb heat from the space, the more air to exchange the more efficient the system will operate.

Note: Avoid attempting to camouflage the unit. This will restrict airflow and thus the systems ability to work efficiently.

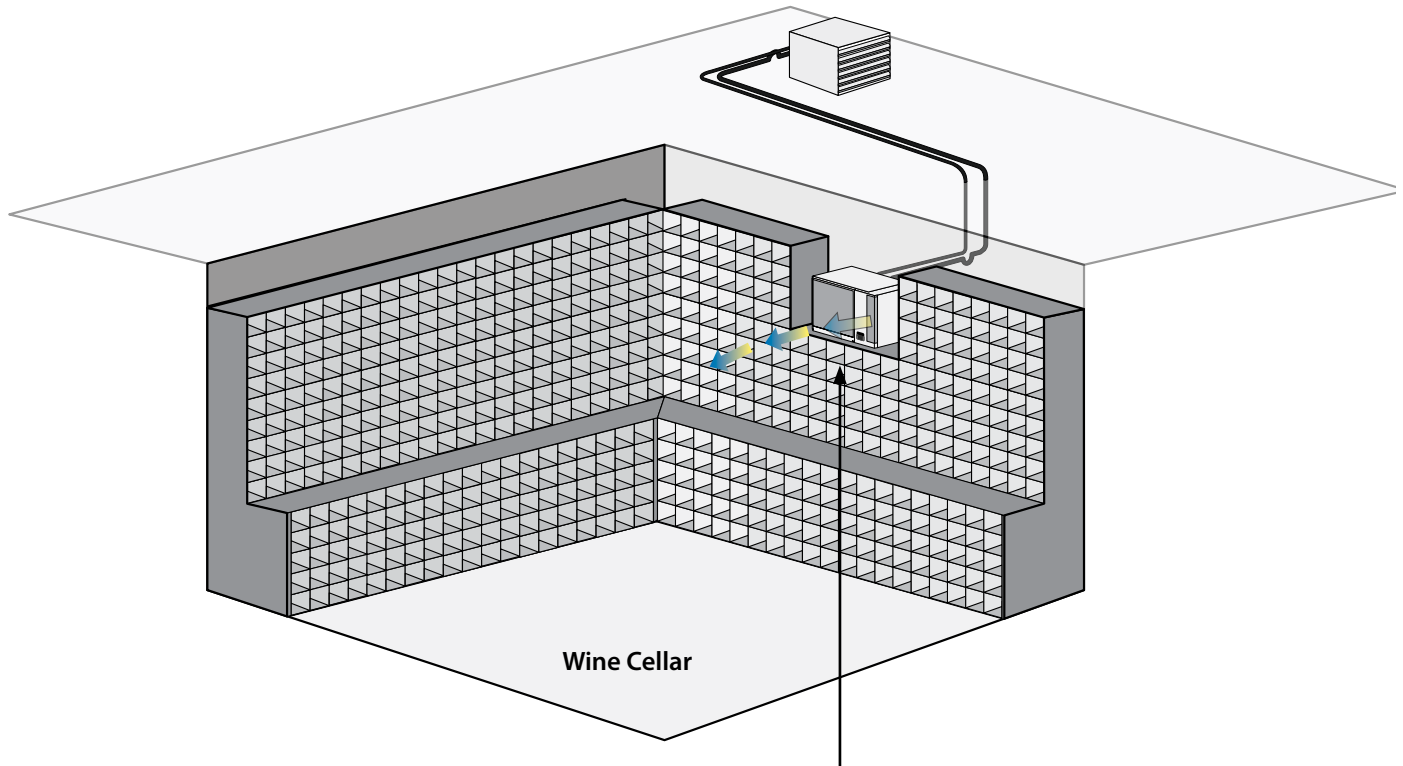

Mounting the Evaporator Unit (Fan Coil Unit)

The Evaporator Unit (Fan Coil Unit) must be mounted within 18" of the top of the room in order to achieve sufficient cooling. As the room cools down, the warm air will rise to the ceiling. Mounting the unit high in the room will contribute to a consistently cool environment by capturing the warm air and replacing it with cool air. Mounting the unit low in the room will result in a temperature variation in the room due to the unit's inability to draw warm air from the ceiling of the cellar to the unit itself, and cold air settling to the floor.

Door and Door Seal

An exterior grade (1 3/4") door must be installed as a cellar door. It is essential that weather stripping is attached to all 4 sides of the doorjamb. A bottom "sweep" or threshold is also required. The door must have a very good vapor seal to prevent warmer moist air from leaking into the cellar. One of the most common problems with cooling systems running continually is due to the door not sealing properly. **In cases where glass doors are used and the room size is close to the recommended system size, the next larger size WhisperKOOL system should be used.** This will compensate for the insulation loss due to the lower insulating rating of glass.

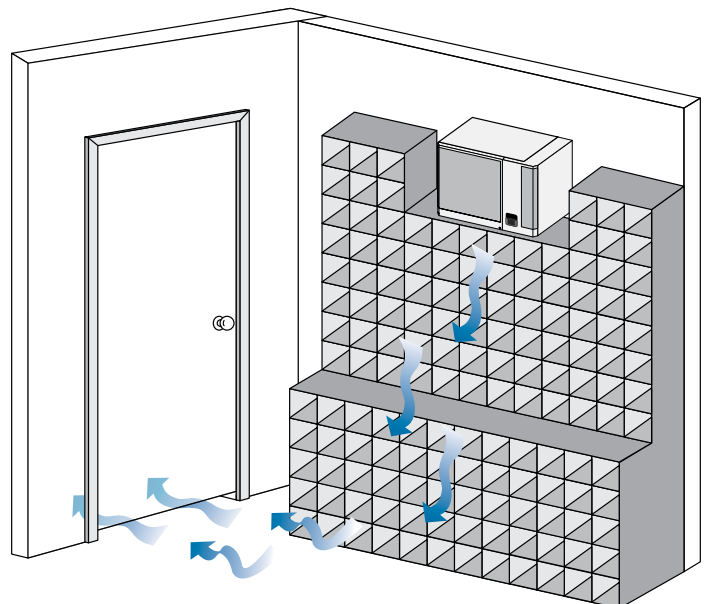

NOTES

PREPARING THE EVAPORATOR UNIT (FAN COIL UNIT)

1

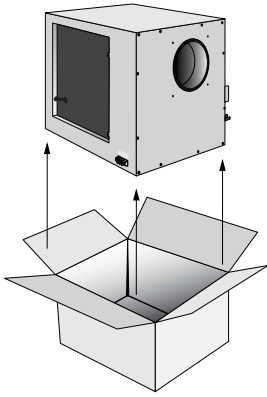

Tools Needed For Brazing:

- Torch
- Brazing Rod
- Wet Rag
- Inspection Mirror
- Nitrogen Tank

Remove the unit from the packaging. Gather all material needed for brazing purposes.

Remove Protective Caps

2

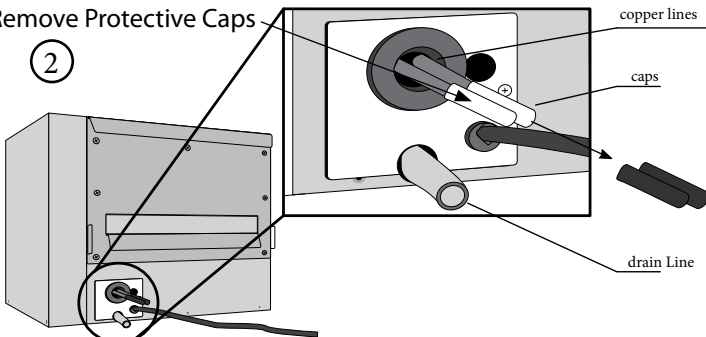

Note: Do not remove the caps until you are ready to perform the brazing process.

3

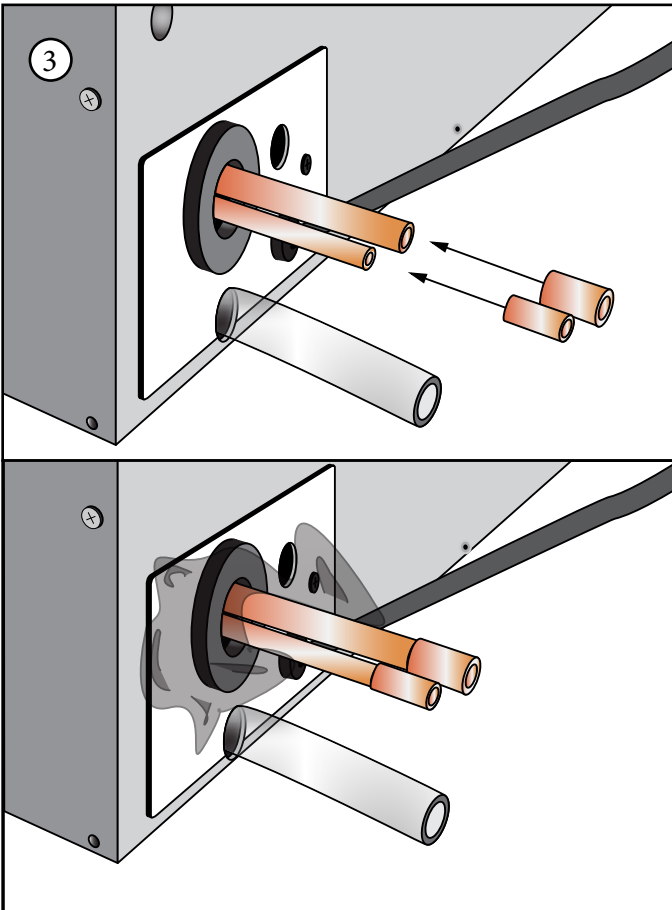

Place both the 3/8 and the 1/4 copper couplings on the exposed lines.

4

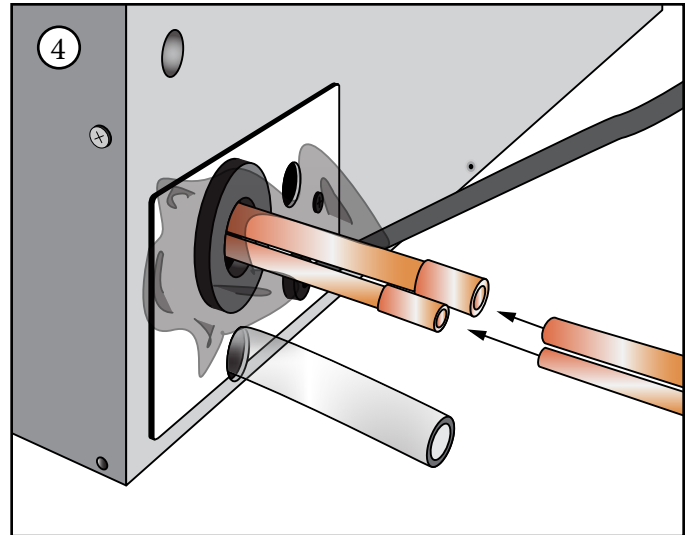

Insert the supplied 10" copper lines into the couplings.

5

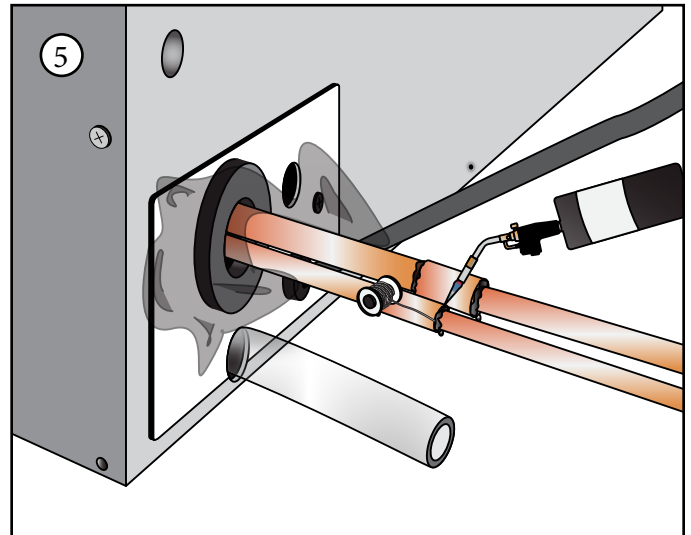

To prevent oxidizing, purge nitrogen into each line. Braze each of the copper extensions to the tubing coming out of the Evaporator Unit (Fan Coil Unit). Perform a visual inspection and pressurize test to 200 psig for 15 minutes to verify there are no leaks.

NOTE: Place a wet rag around the copper tubes near the rubber grommet located at the rear of the evaporator housing, this will minimize the possibility of melting the grommet. Be sure to clear the power cord and drain line from brazing area.

PREPARING THE EVAPORATOR UNIT (FAN COIL UNIT)

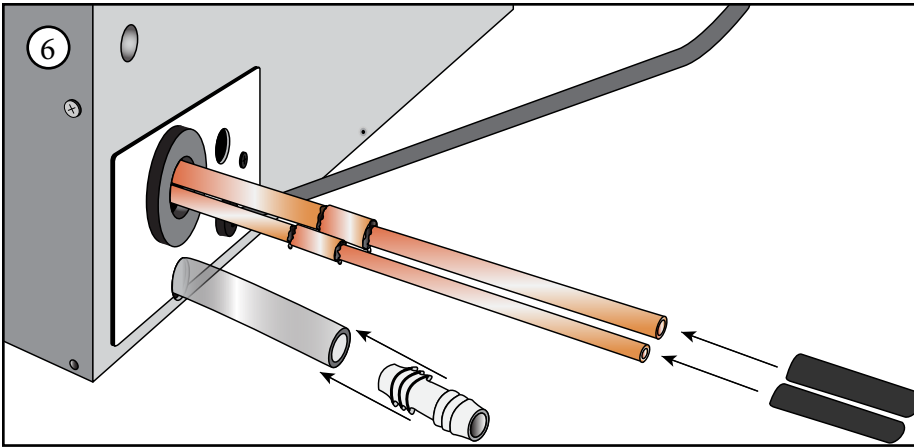

Place the caps removed in step 1 onto the ends of the lines to avoid debris from entering the lines, followed by inserting the barbed coupling into the drain line at the rear of the unit.

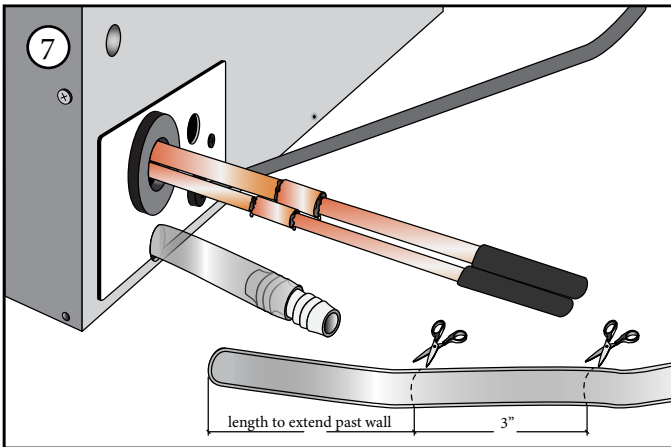

Cut supplied drain tubing at a length long enough to extend past exterior wall and a second piece three inches long.

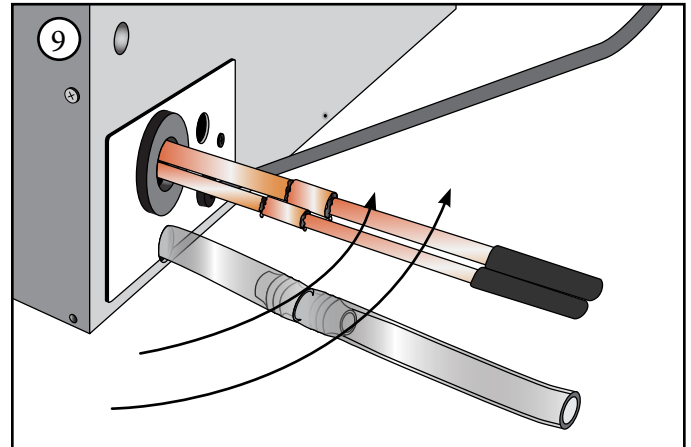

Rotate the unit to access the side panel.

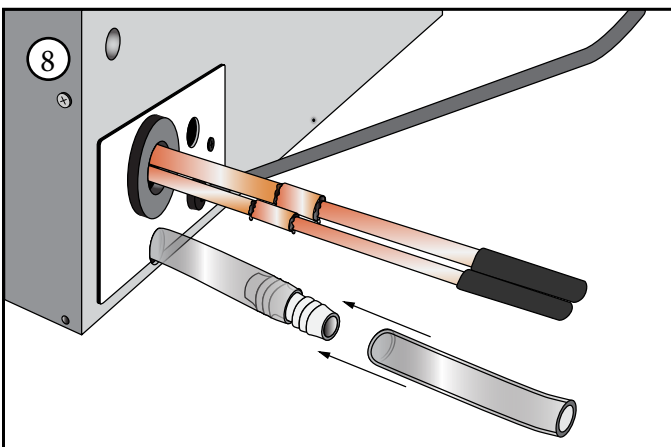

Set the three inch piece aside and attach the piece of tubing that was cut to go through the wall to the end of the barbed coupling.

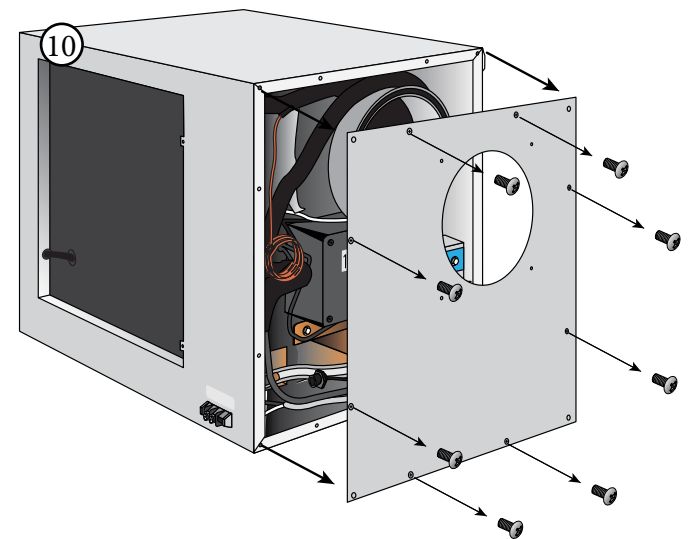

Remove the side panel by removing the eight Phillips head screws around the parameter of the side panel. Set the side panel and screws aside.

PREPARING THE EVAPORATOR UNIT (FAN COIL UNIT)

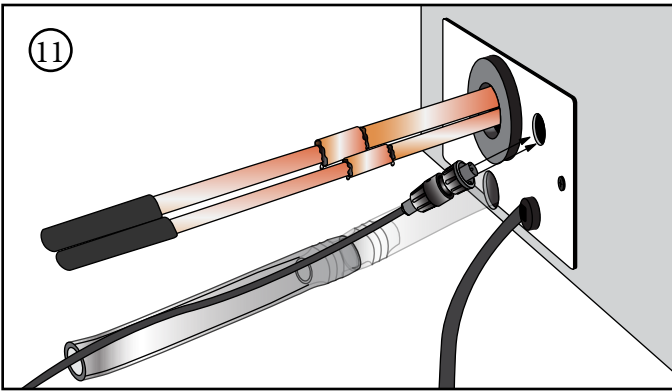

Insert bottle probe connector through the opening on the rear panel.

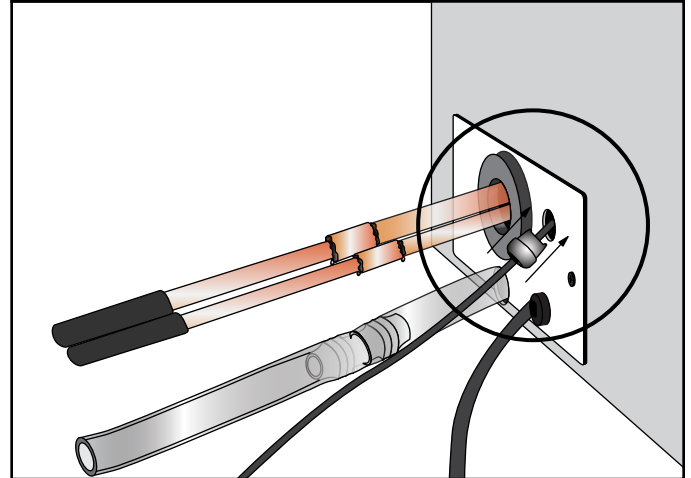
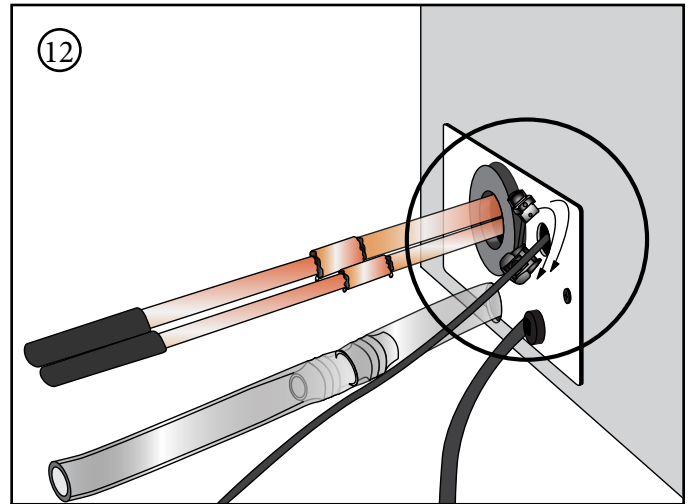

Install the supplied strain relief to secure probe wire. Using pliers, clamp the strain relief around the probe wire and insert the strain relief into the hole the probe wire is coming from. (Note: Strain Relief will snap in to place when fully inserted. Perform a pull test to ensure the strain relief connection is tight.)

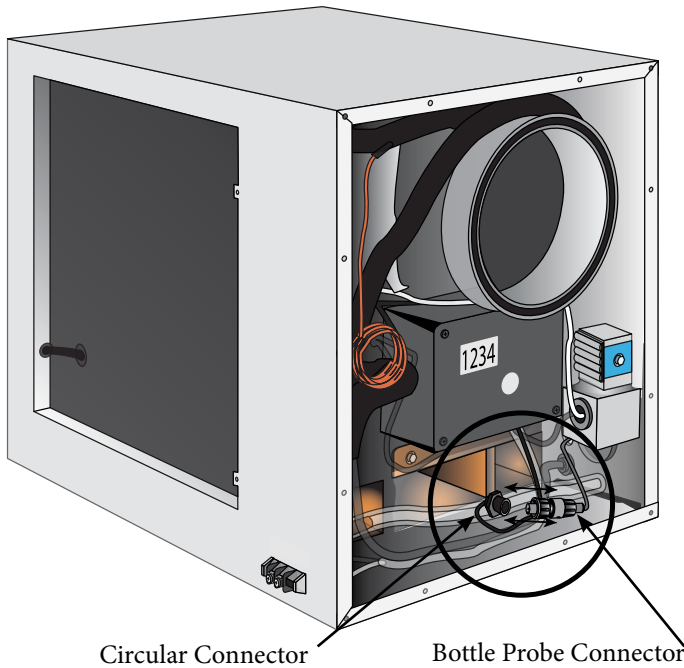

Connecting the bottle probe to the circular connector: Insert the bottle probe connector into the circular connector and twist the bottle probe connector clock wise to lock in place.

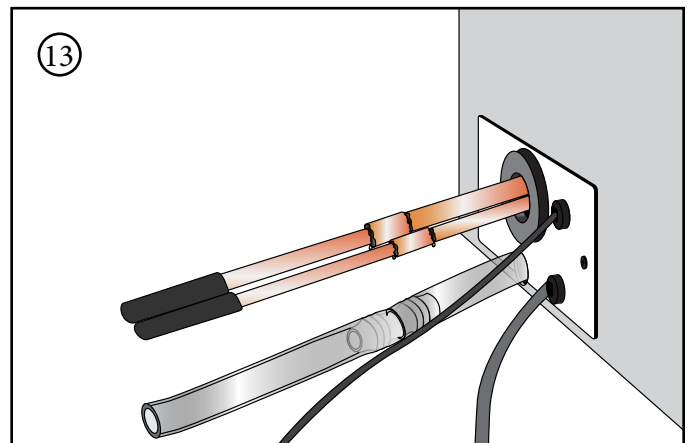

INSTALLING THE EVAPORATOR UNIT (FAN COIL UNIT)

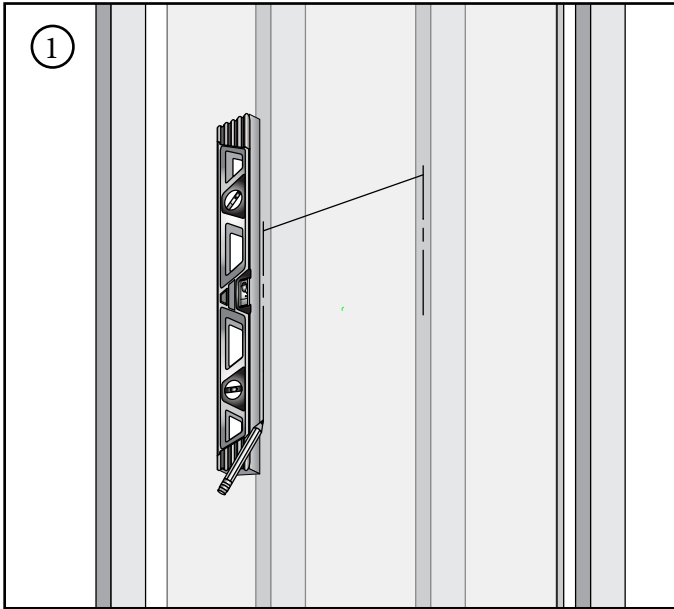

Locate the two desired wall studs. Mark the center line on each stud vertically on the wall (14.5 inches apart). Connect the two lines by using a level draw a horizontal line at your desired height.

NOTE: The top of the unit needs to be installed with a minimum of six inches and a maximum of eighteen inches from the ceiling. (This will ensure the unit is accessible for servicing, as needed.)

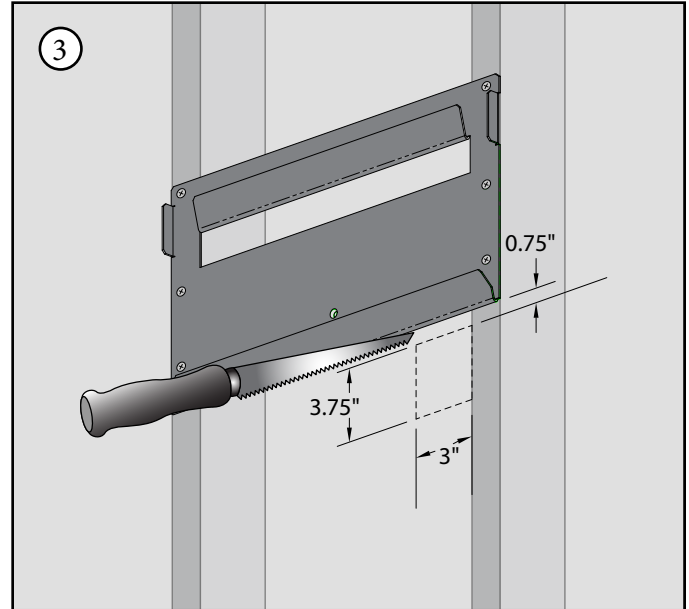

Cut a 3x3.75 inch access hole for routing the line set, power cord, and drain line.

The wall is ready to have the Evaporator Unit (Fan Coil Unit) installed.

NOTE: WhisperKOOL recommends elevating the unit close to the install height.

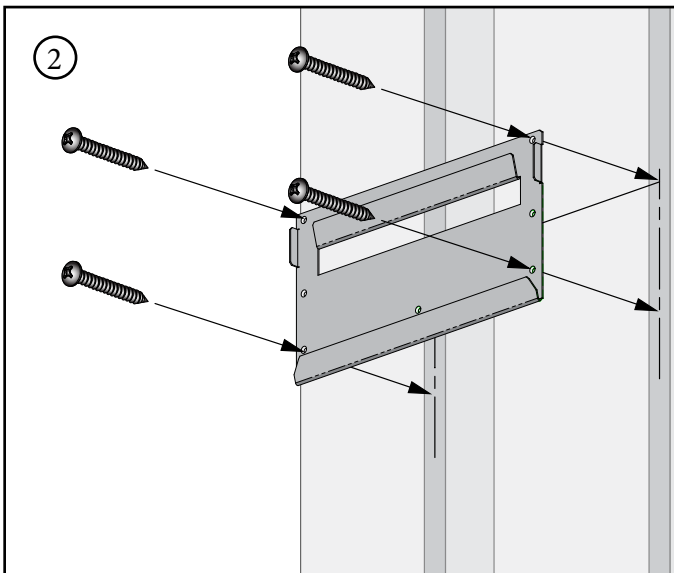

Drill two 5/32" pilot holes for the top mounting screws and then place the mounting plate on the wall and screw in the #14 screws. Finish drilling the four remaining 5/32" pilot holes, followed by screwing in four #14 screws.

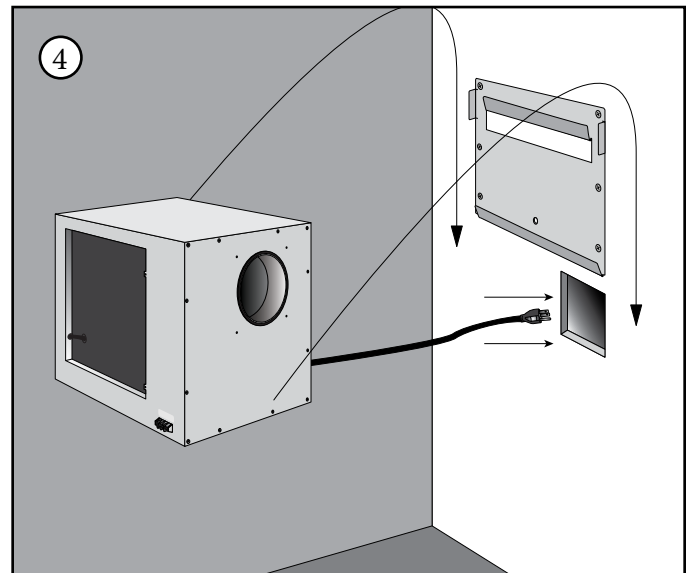

Route the power cord and drain line through the access hole.

INSTALLING THE EVAPORATOR UNIT (FAN COIL UNIT)

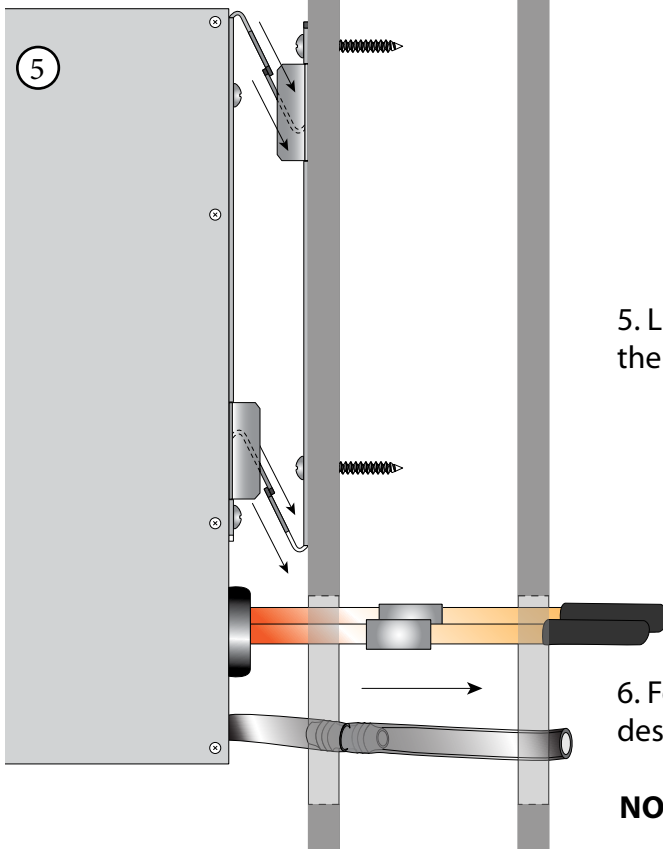

5. Lift the Evaporator Unit (Fan Coil Unit) up and place onto the wall bracket.

NOTE: Be sure that the power cord and drain line stay clear of the bracket contact area

6. Form the copper lines on the outside of the cellar in the desired direction.

NOTE: WhisperKOOL recommends using sweep 90-degree bends when making turns with the line set.

With the system operating, sight glass clear, and the cellar close to 55 degrees Fahrenheit. Check the suction pressure, the temperature of the suction line at the outlet of the evaporator, and if necessary adjust the expansion valve to bring the superheat level between 8-12 degrees.

DRAIN LINE

Condensation Drain Line

The condensation drain line tube is used to remove excess condensation from the Evaporator Unit (Fan Coil Unit) to a proper discharge location. It is important that the drain line tube is properly connected and used to prevent leakage and other problems associated with excess condensation.

Failure to use the condensation drain line tube will void the warranty on the unit.

Drain Line

All systems come with a drain line for additional removal of excessive condensate. It is mandatory to install the drain line whether it leads through the wall and out of the cellar or remains inside the cellar. During operation, the cooling system will strip excess water from the air in order to maintain the proper level of humidity within the cellar. However in extreme humidity, additional condensate will be removed. Thus the drain line will prevent overflow and leaking by allowing for discharge of the additional condensate.

Insert the middle barb of the barbed tee fitting into to the end of the drain line coming from the Evaporator Unit (Fan Coil Unit). Rotate fitting so tee is in the orientation shown in the diagram on the left. Connect the three inch piece from step 7 of preparing the Evaporator Unit (Fan Coil Unit), to the barb on top. Connect the remaining "long" piece of drain tubing to the bottom barb of the tee.

NOTE: The fitting should be placed vertical with the three inch cut out facing up.



WRONG: Drain line is under water.



Failure to install the drain line voids the warranty.



To prevent mold from growing, allow the drain line to hang above the water line.

THROUGH THE WALL DRAIN LINE

OPTION 1

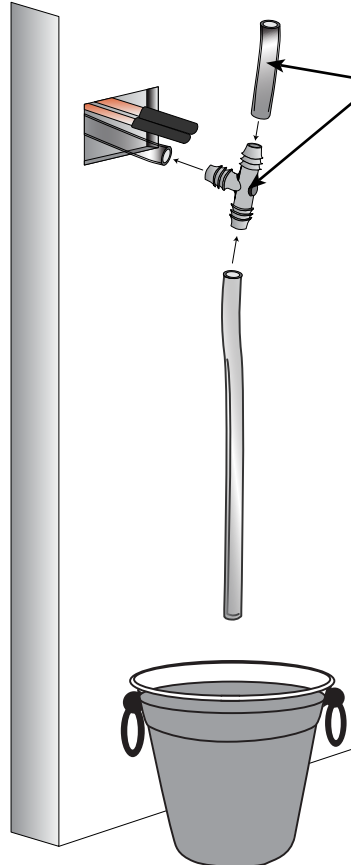

NOTE: The fitting should be placed vertical with the three inch cut out facing up.

INSIDE CELLAR DRAIN LINE

OPTION 2

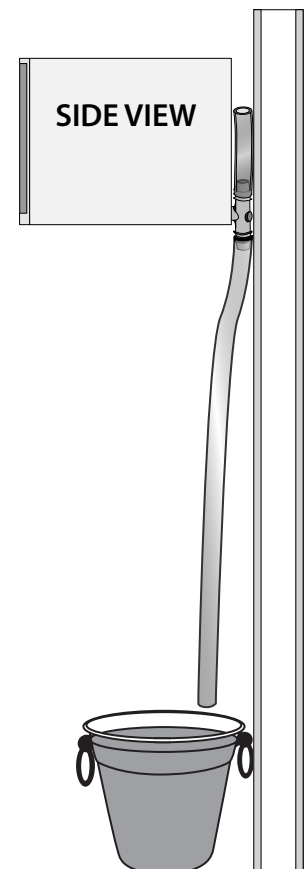

EVAPORATOR UNIT (FAN COIL UNIT) WIRING SCHEMATIC

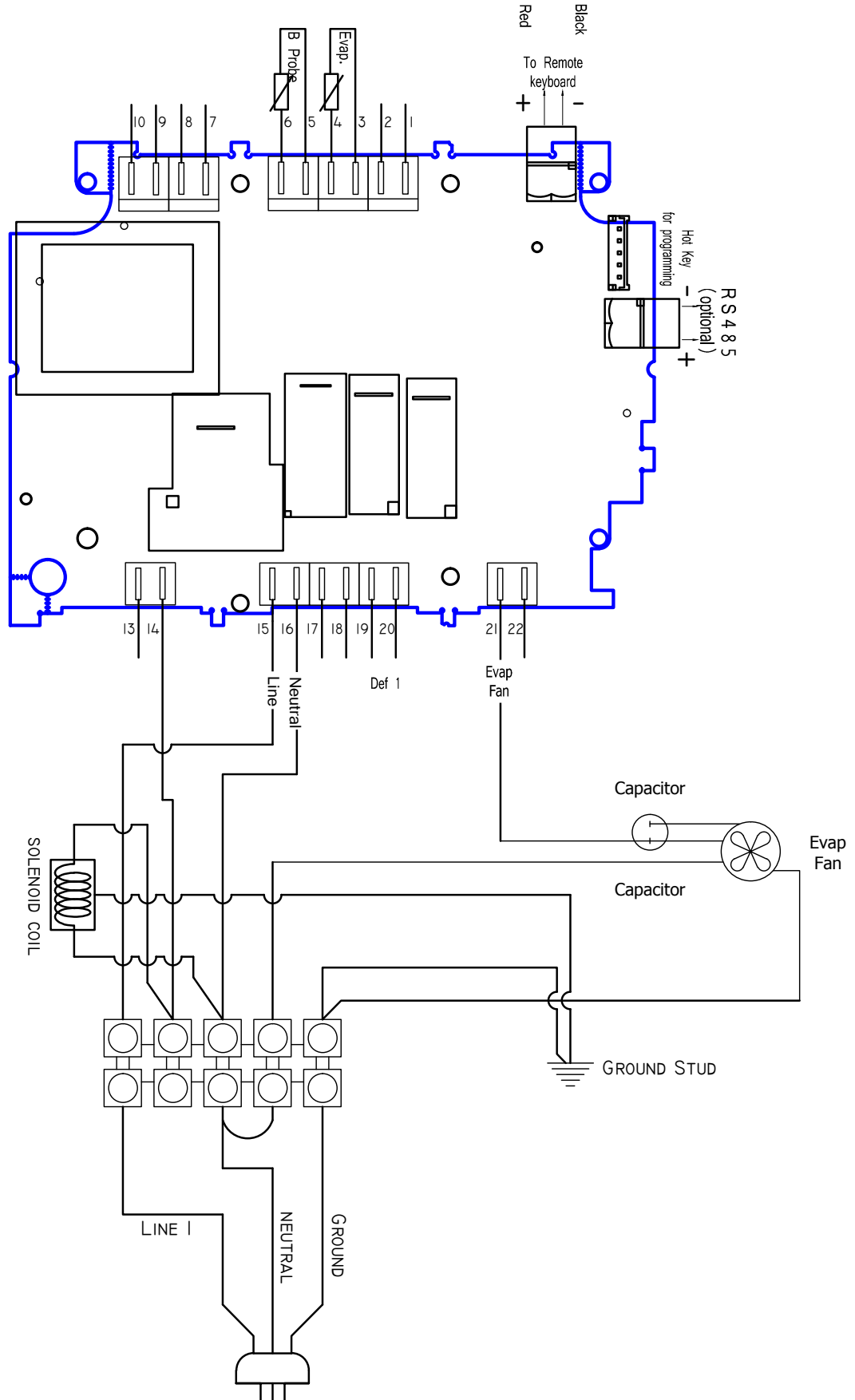

PREPARING THE CONDENSING UNIT

Electrical Needs

The condensing unit requires a dedicated 115 volt, 20 amp circuit. A dedicated circuit breaker ensures that the condensing unit will have sufficient power for effective operation. The compressor is controlled by a low pressure switch mounted on the condensing unit. This feature eliminates the need for wiring between the evaporator and condensing unit.

- Provide an outlet for the condensing unit that matches the plug provided on the unit
- Ensure the voltage supplied matches the rating specified on the unit spec label
- Provide a weatherproof disconnect for condensing units located outside

As with all sensitive electrical equipment, damage may be caused in the event of power surges and spikes. WhisperKOOL recommends plugging the unit into a surge protector, or power conditioner in order to protect your system. As outlined in our Terms & Conditions, power surges and spikes are not covered under warranty.

In case the system should lose power, check the home/main circuit breaker. If the system does not respond properly, refer to the Troubleshooting section on page 34.

QUICK REFERENCE GUIDE

Water Cooled Condensing Unit

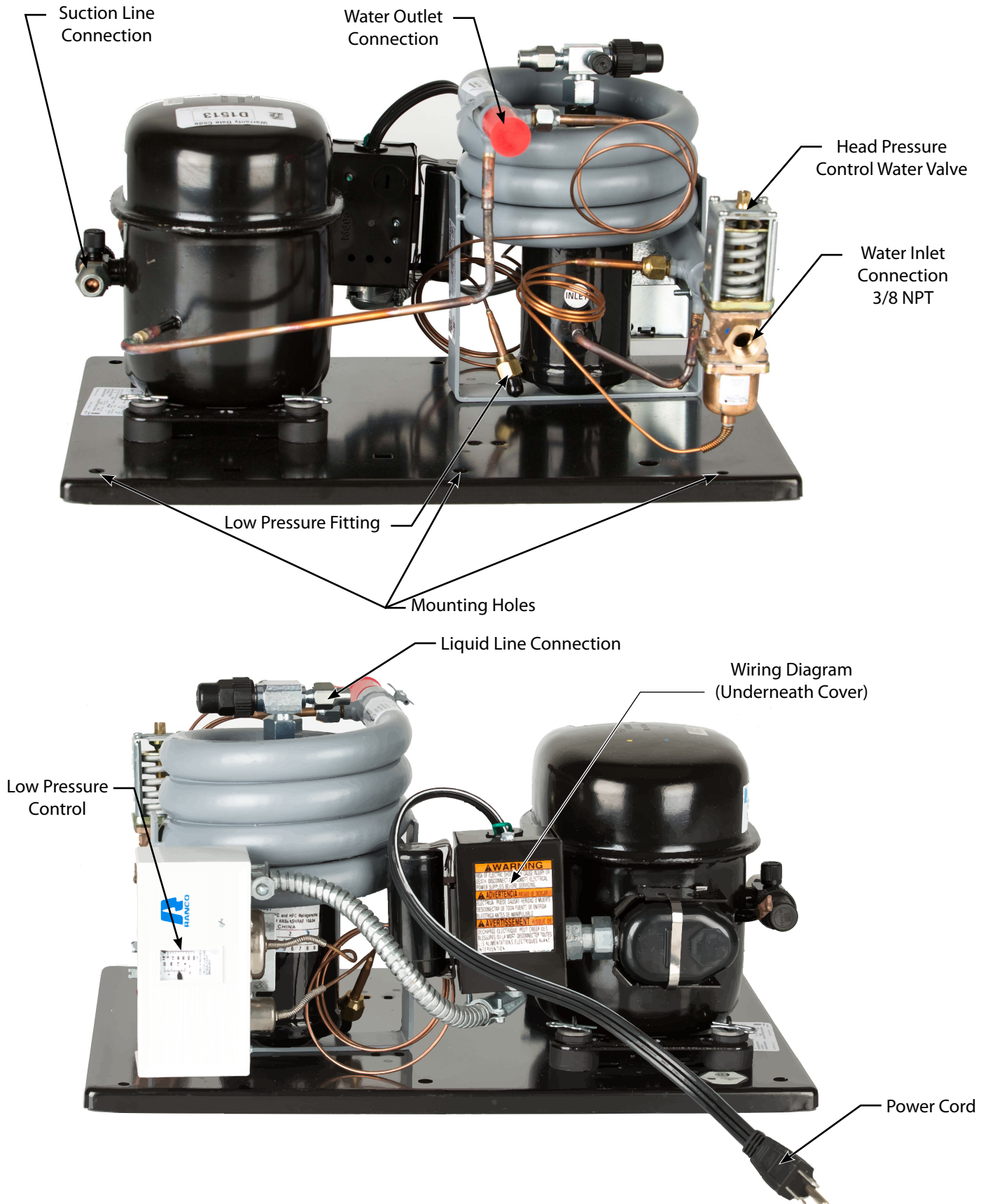

LINE SET PIPING DIAGRAMS

These are two options for running the line set from the coil to the condensing unit. Option 1 is specifically for when the system is installed with the condensing unit below or leveled to the coil. Option 2 is for when the system is installed with the condensing unit at a higher elevation than the coil.

SINGLE FAN COIL PIPING SYSTEM
 CONDITION: CONDENSING UNIT BELOW OR CLOSE TO SAME
 ELEVATION AS FAN COIL UNITS

Option 1

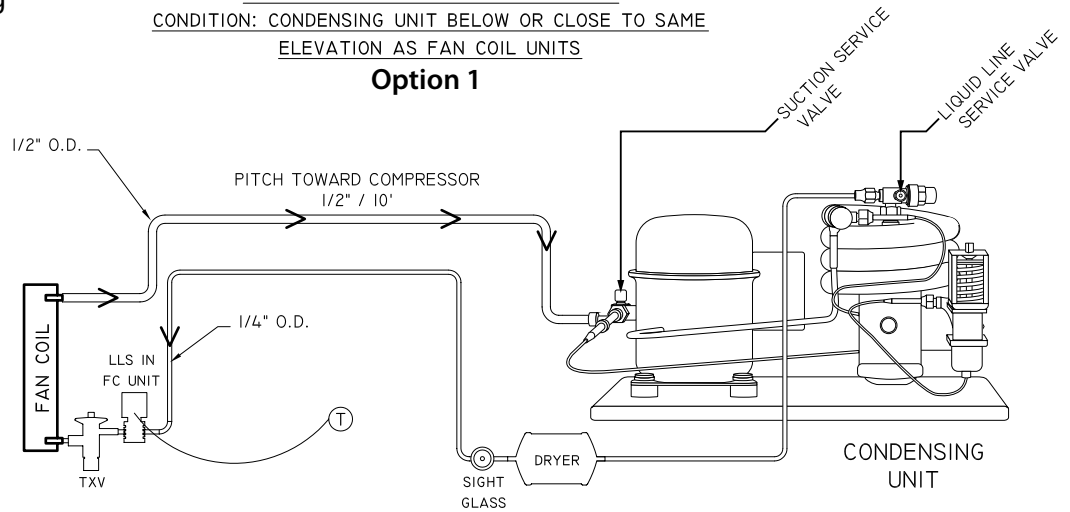

SINGLE FAN COIL PIPING SYSTEM
 RECOMMENDED REFRIGERANT PIPING DESIGN FOR CONVENTIONAL FACTORY SUPPLIED FAN COIL AND WATER COOLED CONDENSING UNIT COMPONENTS. REFRIGERANT LINE LENGTHS IN EXCESS OF 90' NOT RECOMMENDED.

THIS DRAWING APPLIES TO CONDENSING UNIT LOCATION AT OR BELOW THE ELEVATION OF THE FAN COIL UNIT. SUCTION PIPE TO BE INSULATED WITH 1/2" WALL INSULATION (ARMAFLEX BRAND) OR EQUAL.

LEGEND	
LLS	Liquid Line Solenoid
TXV	Thermal Expansion Valve
COMP	Compressor
REC	Receiver
EVAP.	Evaporator
O.D.	Outer Diameter

SINGLE FAN COIL PIPING SYSTEM
 CONDITION: CONDENSING UNIT ABOVE FAN COILS AND
 VERTICAL PIPES HAVE GREATER THAN 3' RISE.

Option 2

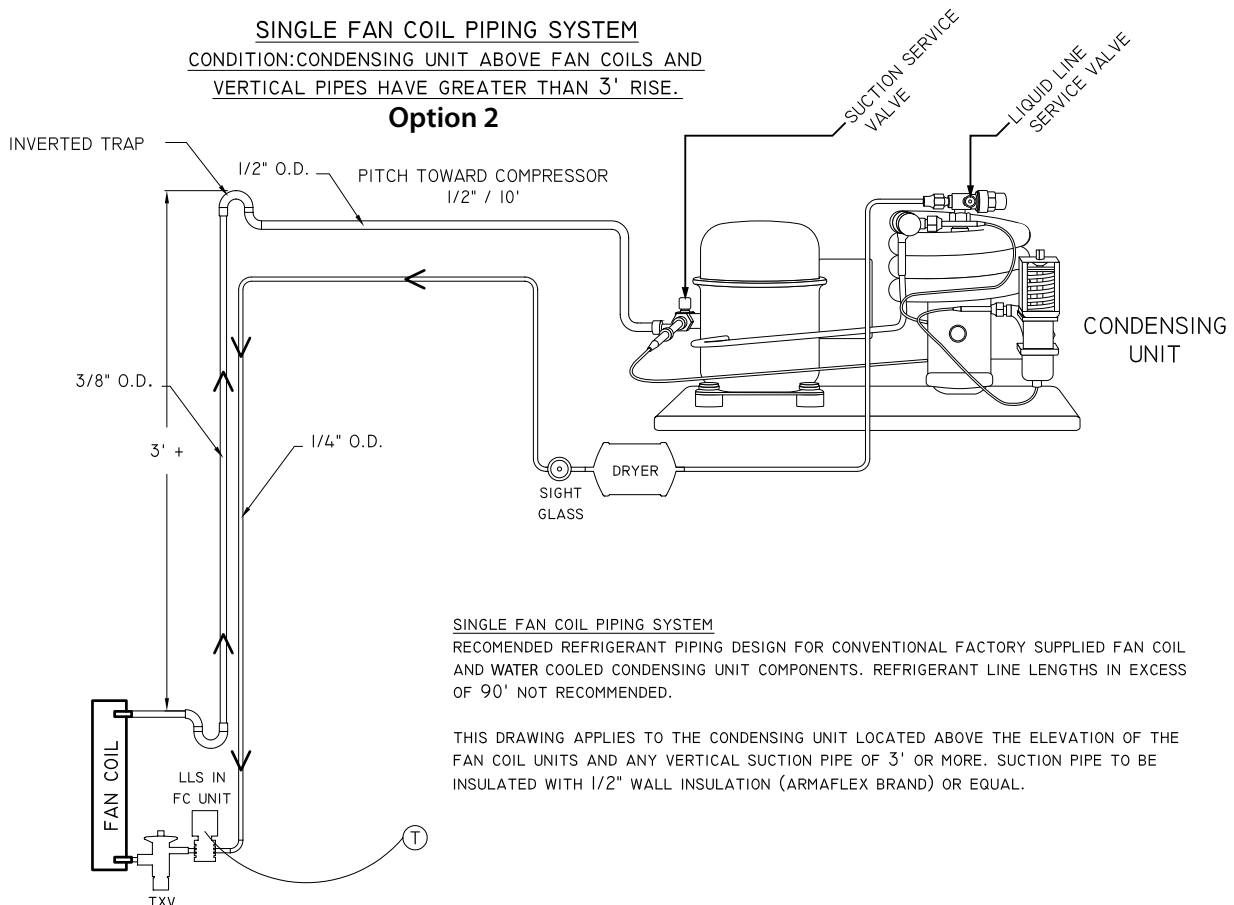

SINGLE FAN COIL PIPING SYSTEM
 RECOMMENDED REFRIGERANT PIPING DESIGN FOR CONVENTIONAL FACTORY SUPPLIED FAN COIL AND WATER COOLED CONDENSING UNIT COMPONENTS. REFRIGERANT LINE LENGTHS IN EXCESS OF 90' NOT RECOMMENDED.

THIS DRAWING APPLIES TO THE CONDENSING UNIT LOCATED ABOVE THE ELEVATION OF THE FAN COIL UNITS AND ANY VERTICAL SUCTION PIPE OF 3' OR MORE. SUCTION PIPE TO BE INSULATED WITH 1/2" WALL INSULATION (ARMAFLEX BRAND) OR EQUAL.

INSTALLING THE CONDENSING UNIT

It is required to size the suction line tubing according to this chart.

Model	Line Set Length	<25ft			26-50ft			50-100ft		
	Vertical Rise	<3ft	3-10ft	>10ft	<3ft	3-10ft	>10ft	<3ft	3-10ft	>10ft
Platinum Split 4000 WC	Horizontal Tubing	1/2"						5/8"		
	Vertical Rise	3/8"						5/8"	1/2"	

The refrigerant drier and the sight glass shall be installed (in that order) in the direction of the refrigerant flow in the liquid line between the condensing unit and Evaporator Unit (Fan Coil Unit). Enclose the suction line in a cellular insulation 1/2" wall thickness Armaflex (brand name) or equal to reduce heat transfer.

Most water cooled units are installed indoors. Since this unit rejects all of its heat to a water source, there is no need to provide special ventilation when installing indoors. If this unit is installed outdoors it must be installed in a location which shelters it from adverse conditions such as direct sunlight and rain.

Using the mounting holes located in the base, fasten the condensing unit to a secure foundation.

Refrigerant Piping Overview

- Using the charts and illustrations found on the previous page, route the line set between the evaporator unit and condensing unit. Be sure to reference the chart for correct line set sizing. All horizontal suction piping should be pitched toward the condensing unit 1/2" for every 10' of pipe. When installing and routing the line set, cap both ends of each tube to prevent debris from entering the tubing.
- Prior to connecting the piping to the evaporator and condensing units, loosely connect a refrigerant manifold to the suction and liquid line service valves.
 - Purge the hoses with dry nitrogen and tighten the hose connections.
 - Remove the service valve caps and turn the valve stem clockwise 1/2 turn to unseat the valve and open the service port. Keep the piping ports sealed until ready to braze.
- Purge dry nitrogen through the fittings at a slow rate to prevent formation of highly abrasive copper oxide.
- Perform all brazes.
- Pressure test the system and check for leaks.
- Insulate the suction line using 1/2" wall cellular insulation or equivalent. Seal all seams with Armaflex 520 Foam Insulation Adhesive or equivalent. Wrap each seam using line set tape.

Liquid Line Piping Procedure

- 1/4" OD copper tubing is required for the liquid line on all systems.
- Flare a short piece of 1/4" copper tubing.
- Remove the flare nut from the fitting on the liquid line valve.
- Slide the nut over the piece of tubing and attach the tubing to the fitting on the liquid line valve.
- Connect the supplied refrigerant drier to the tubing.
- Downstream from the drier, connect the moisture indicating sight glass in an easily visible location
- Run the tubing to the evaporator unit (fan coil unit) and attach to the liquid line connection on the evaporator unit (fan coil unit).

Suction Piping Procedure

- Flare a short piece of 3/8" or 1/2" copper tubing. The correct size will depend on your model type.
- Remove the flare nut from the fitting on the suction line service valve.
- Slide the nut over the piece of tubing and attach the tubing to the fitting on the suction line service valve.
- Install an access valve close to the tubing and another at the outlet of the evaporator unit (fan coil unit).
- Run the pre-insulated suction line to the evaporator unit (fan coil unit) and attach to the suction line connection on the evaporator unit (fan coil unit).

INSTALLING THE CONDENSING UNIT (continued)

Brazing Procedure

- Connect the bottle probe to the evaporator unit (fan coil unit).
- Fill a wine bottle $\frac{3}{4}$ full of room temperature water. Insert the bottle probe into the neck of the bottle as far as possible. It is important that the bottle probe stopper be compressed by the neck of the bottle to ensure water will not leak.
- Energize the evaporator unit (fan coil unit) and set the controller to call for cooling
- Verify that the set point on the control is set low enough to allow the unit to run for the entire length of the brazing, evacuation and charging procedure.
- Remove the valve depressors from the gauge hoses on a four valve manifold.
- Connect the manifold to the low pressure service valve port on the condensing unit.
- Open the suction line service valve and purge nitrogen through the system.
- Braze all connections and cool off quickly
- Cap both access valves on the suction line
- Connect the high pressure hose from the manifold to the liquid line valve port.
- Pressure test the system at 150 psi for 20 minutes
 - Check all braze joints with leak detector or soap bubbles
- Release the nitrogen once it is confirmed that there are no leaks

Evacuation

- Install the low pressure fitting onto the access valve near the suction line service valve.
- Install a micron gauge onto the access valve near the evaporator unit (fan coil unit).
- Mid seat both service valves.
- Install service caps on the valves.
- Energize the liquid line solenoid valve.
- After confirming there is fresh oil in the vacuum pump, connect the 3/8" hose from the manifold to the pump.
- Start the pump and run until the micron gauge at the evaporator unit (fan coil unit) reads 200 microns or less.
- Disconnect the vacuum pump from the system.
- Break the vacuum by pressurizing the system to approximately 5 PSI with R-134a.
- Remove the micron gauge from the access valve.

Water Piping Procedures

- While unit is pulling a vacuum, install all water line connections.
- If the supply water is above 80 psi, a pressure reducer must be installed before the condenser inlet so that the water valve will work properly.
- Installations in closed loop systems should have bleed valves and sediment traps to prevent fouling the condenser with suspended matter.
- Connect a minimum 3/8" water line capable of supplying at least 1 gpm to the 3/8 NTP water inlet connection on the condensing unit. **There must be sufficient water flow so that the outlet temperature does not exceed 95°F.**
- Connect copper, Pex or similar tubing in accordance with local laws capable of handling hot water to the water outlet connection of the condensing unit.
- Turn on the water supply and check for leaks.

INSTALLING THE CONDENSING UNIT (continued)

Charging

- Install a low pressure gauge on the access valve near the evaporator unit (fan coil unit).
- With the power off to the condensing unit, admit liquid refrigerant through the liquid line service valve until the refrigerant stops flowing.
- Verify that the low pressure control is set to 20 PSI for high event and 15 PSI for the differential.
- Plug in the condensing unit to a dedicated 20 amp electrical outlet. The compressor should turn on if the pressure in the suction line is above 20 psi.
- Add refrigerant as a vapor through the low side of the system.
- Observe the sight glass. If bubbles are present, add more refrigerant in vapor form to the low side.
- Once the sight glass is clear, check the superheat at the outlet of the evaporator unit (fan coil unit). **Adjust the TXV until the superheat is between 8-12 degrees.**
- Adjust the head pressure control until the head pressure is 125 PSI. **The head pressure control must be set to maintain a head pressure no higher than 150 PSI.**

Reinstall the Evaporator Unit (Fan Coil Unit) panel that was removed in step (10) on page 10. Confirm the controller is displaying the correct temperature and that the controller is not displaying an alarm. If the controller is displaying an alarm reference page 32 for corrective action. Confirm that the suction line is completely insulated, from TXV to compressor. Confirm that the sight glass has no bubbles and the ambient temperature around the condensing unit is not getting excessively hotter. Confirm that both king valves have been back seated and the nuts have been installed back on the king service ports.

BEFORE INSTALLING THE WALL MOUNT KIT OR DUCTED CONFIGURATION OPTIONS

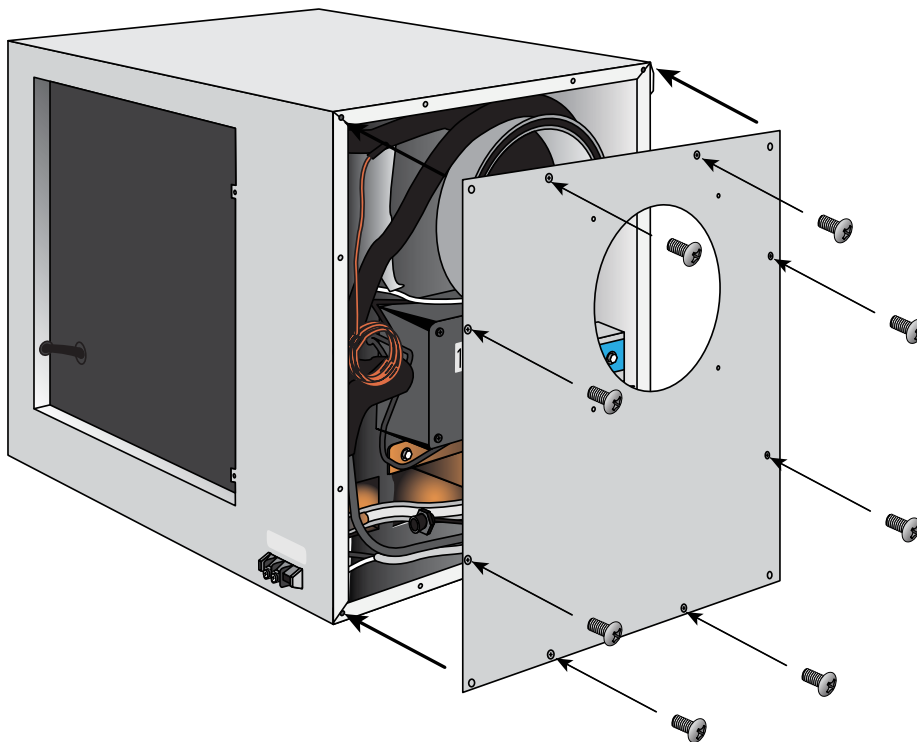

Secure the Side Panel by installing the eight Phillips head screws around the parameter of the side panel.

NOTES

QUICK REFERENCE GUIDE

Wall Mount Kit Option (Installed)

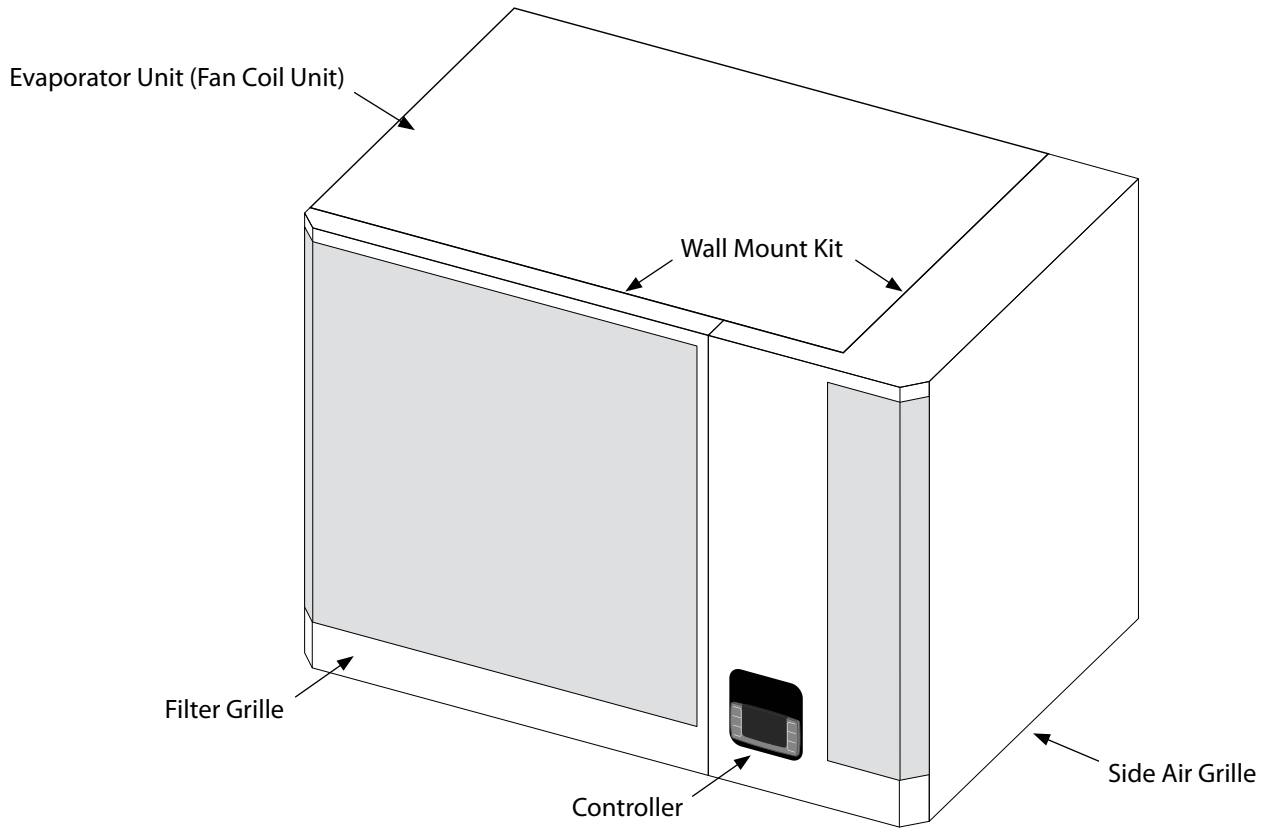

Rear / Side View

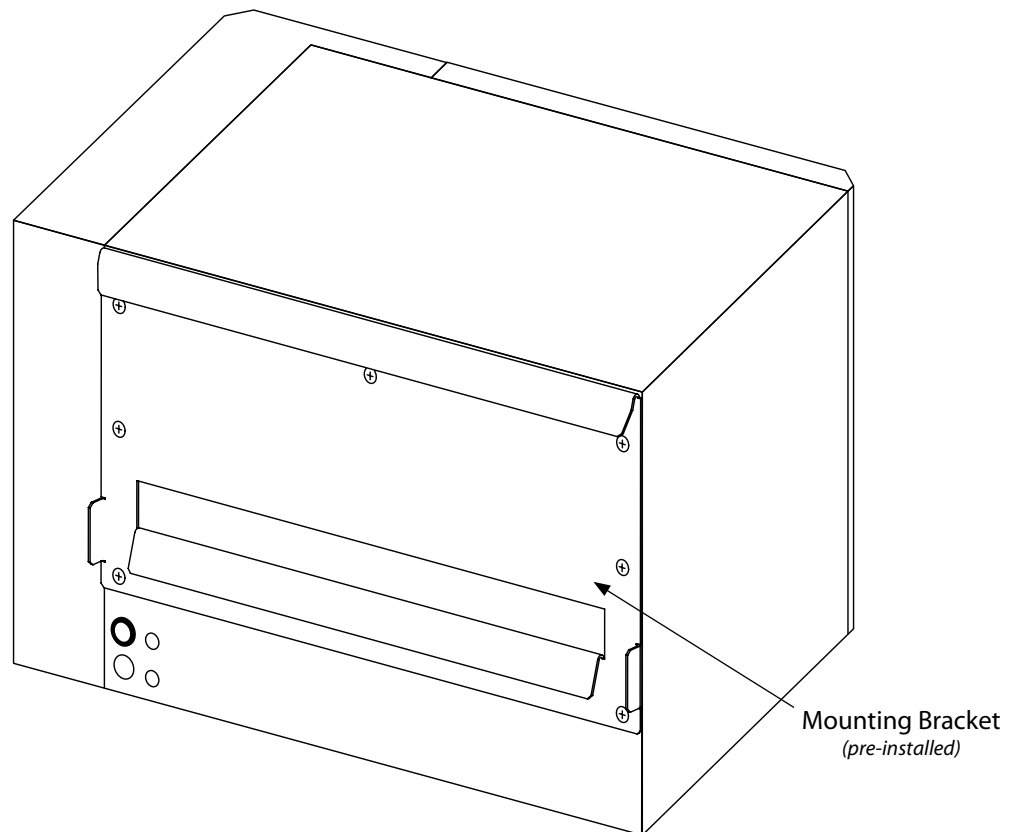

INSTALLING THE WALL MOUNT KIT

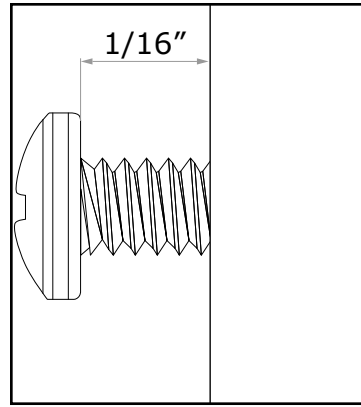
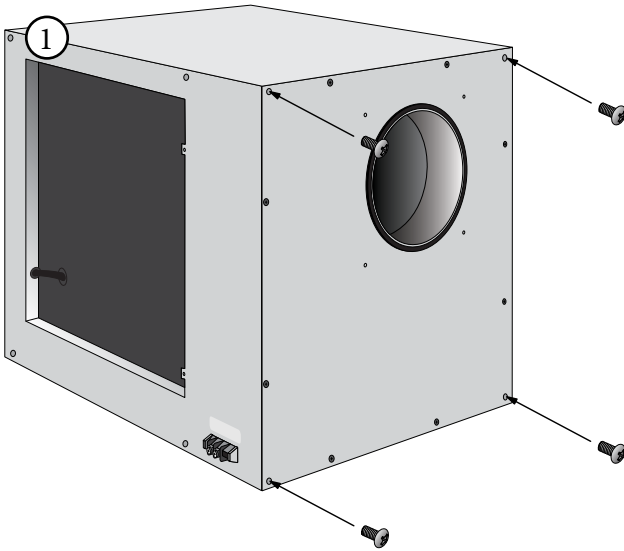

NOTE: The screws should be installed with about 1/16" between the face and screw head.

Install one of the 6-32 3/8" Phillips Pan Head screws, in each corner of the supply panel.

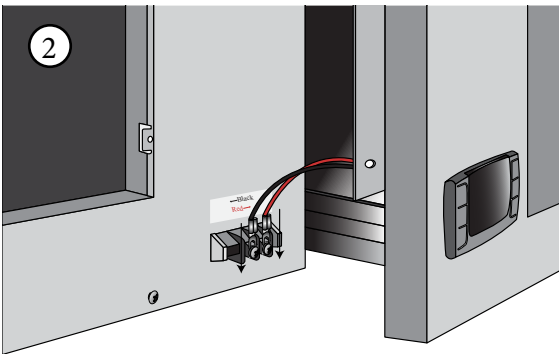

Connect the two wires from the keypad to the terminal block. (Note: If the display does not illuminate on initial start up, reverse the connection of the two wires.)

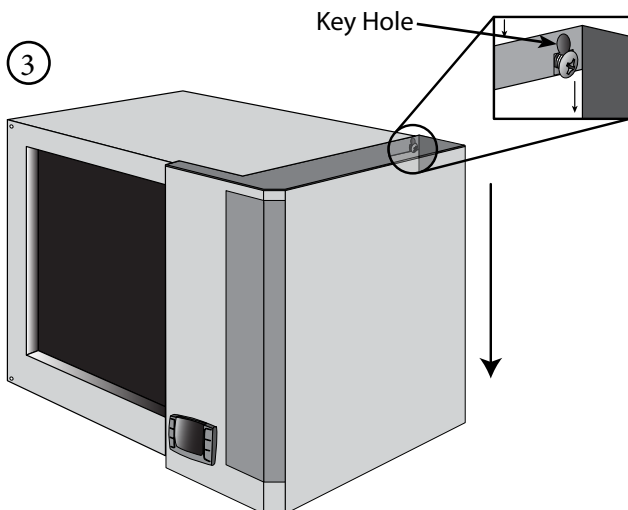

Mount the side air grille by aligning the four key holes with the four mounting screws and slide down. Tighten the bottom two screws and slide down. Tighten the bottom two screws through the access holes once the side air grill has been slid into place.

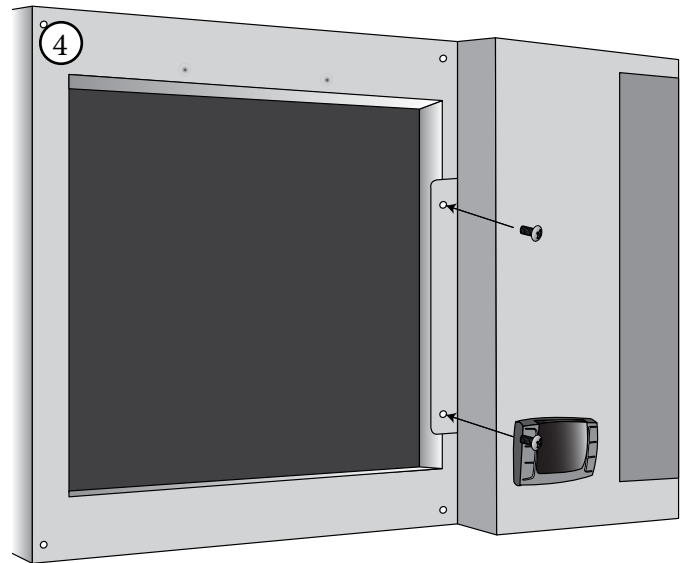

Install two of the 6-32 3/8" Phillips pan head screws in the front to completely secure the side air grille to the Evaporator Unit (Fan Coil Unit).

INSTALLING THE WALL MOUNT KIT

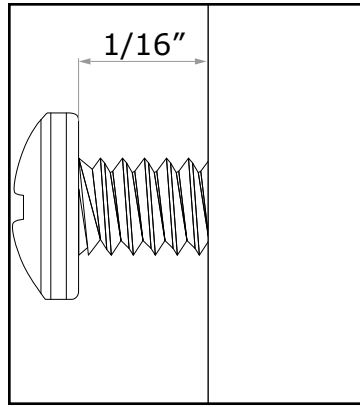
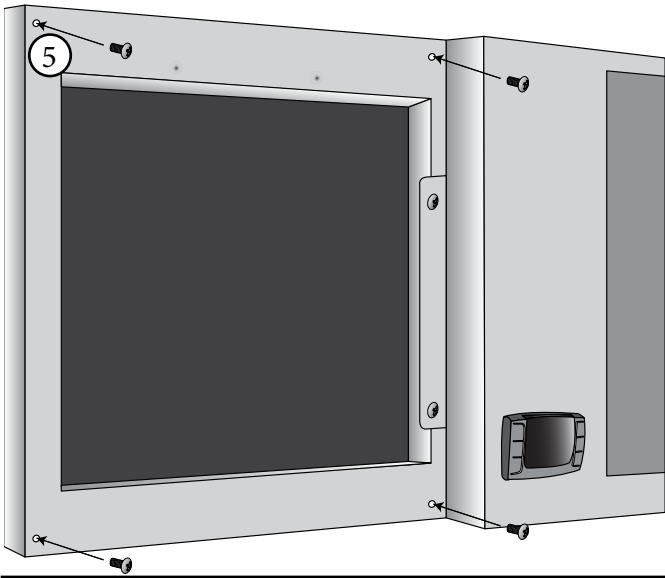

NOTE: The screws should be installed with about 1/16" between the face and screw head.

Install the remaining four 6-32 3/8" Phillips pan head screws in the four corners on the front of the Evaporator Unit (Fan Coil Unit).

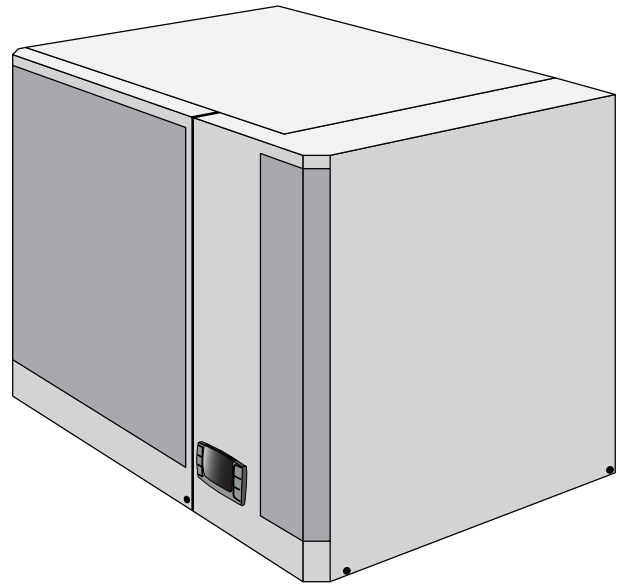
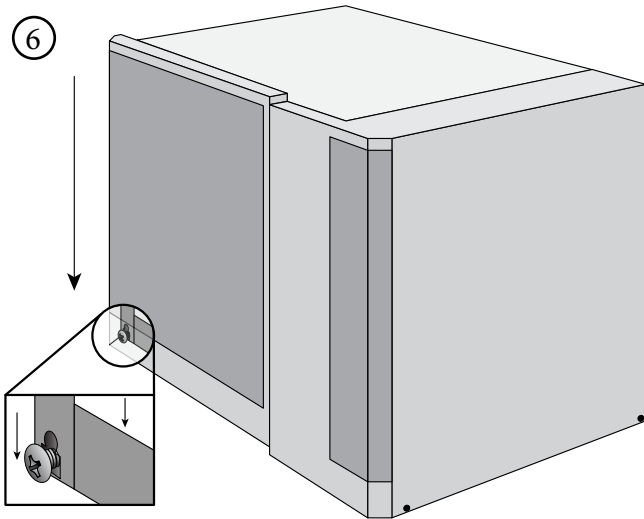

Install the Filter Grille by aligning the four inside slotted holes with the four mounting screws and slide down. Tighten the bottom two screws through the access holes when the grille is already in place.

WALL-MOUNT PLATINUM SPLIT

FULLY DUCTED INSTALLATION INFORMATION

Ducting the supply and return air to the cellar creates a virtually silent cellar space and also maximizes cellar capacity. It is absolutely crucial to only use insulated duct work as it minimizes cooling loss, prevents sweating, and reduces noise. Failure to use insulated ducting will cause the unit to run excessively and greatly shorten its lifespan.

Note: Do not exceed a total of 25 duct feet between the Evaporator Unit (Fan Coil Unit) and cellar vent, this means a total of 50' combined for both the supply and return lengths.

Avoid crimping the flexible ducts. This chokes down the inside area and reduces the airflow causing the unit to lose efficiency. Be sure all ducts and surfaces in contact with the airflow are insulated and have a vapor barrier on the outside.

Un-insulated ducts and surfaces cause bare, exposed metal surfaces to sweat, further degrading the insulation and equipment cooling capacity.

General Duct Recommendations:

- Provide support for the flexible duct to prevent sags and bends
- Stretch out the duct to make a smoother interior, which reduces air resistance
- For 90° bends, use a 90° adjustable elbow (Ell)
- Do not squeeze or reduce the inside diameter of the ducts, which reduces airflow
- Use short and straight duct work where possible
- Remove the grilles and panels from the openings to connect the duct work
- Check that all fan blades move freely
- Keep air paths free of loose foreign objects and debris
- Connect the round flexible ducts to the WhisperKOOL system using the duct collars provided with the duct accessory kit
- Pull the outer plastic wrapping and insulation away from the end of the duct to expose the reinforced inside duct liner
- Fasten the duct collar using tie straps or clamps around the inside liner
- Secure the duct collar to the unit using the screws provided. Take care to not damage or bend the gasket
- Use approved duct tape to seal all joints

Do not clamp around the outside insulation, as it will compress and loosen over time.

Note: When performing a ducted installation, it is crucial not to forget about routing the bottle probe into the cellar. The system must have the sensing bottle in the cellar to maintain the cellar environment.

QUICK REFERENCE GUIDE

Ducted Configuration Option (Installed)

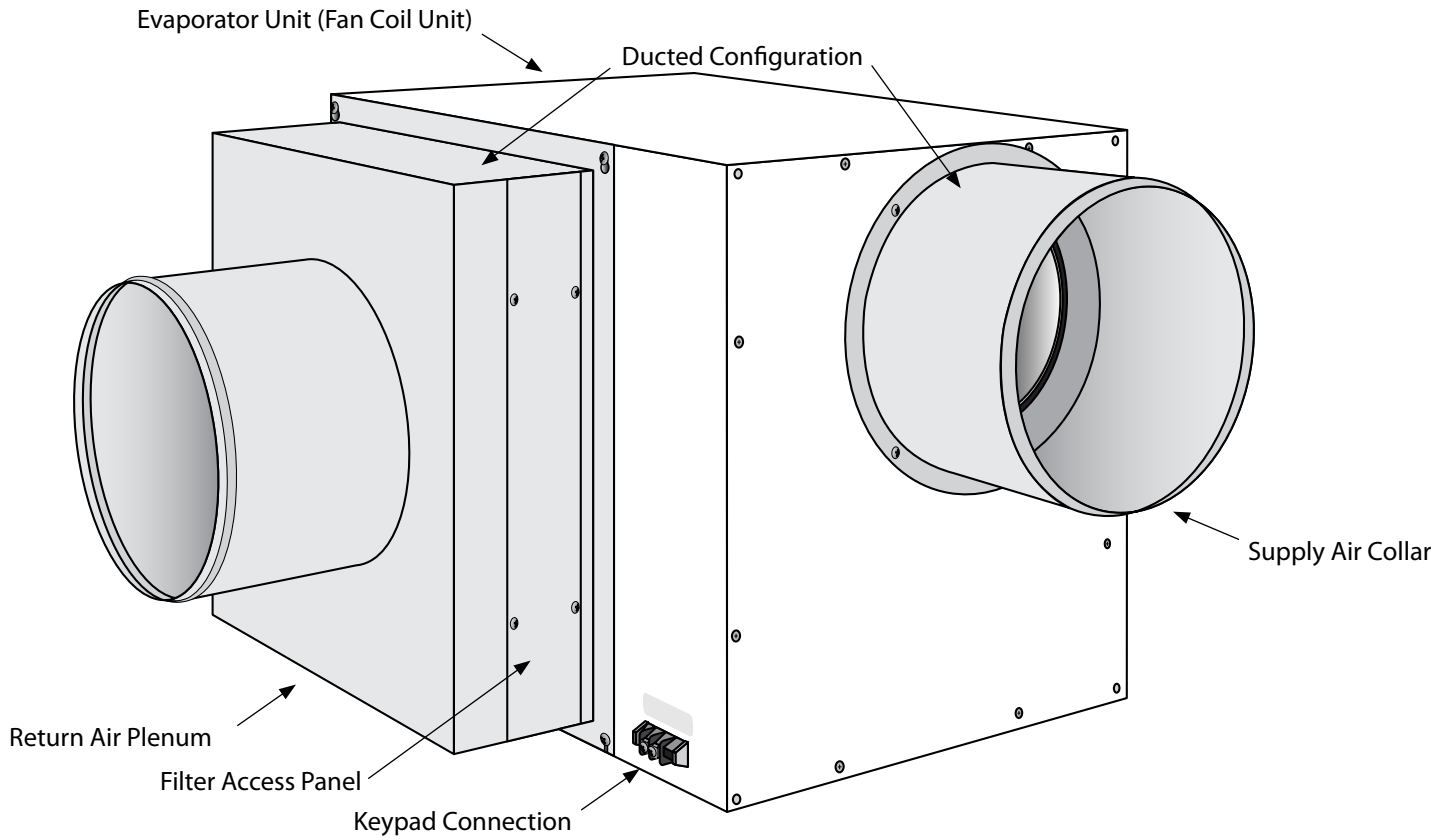

INSTALLING THE DUCTED CONFIGURATION

DUCT CONFIGURATIONS

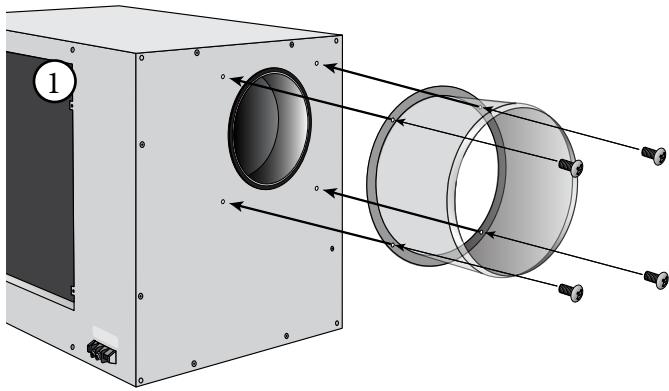

Install the Supply Air Collar by aligning the holes with the Evaporator Unit (Fan Coil Unit) on the side panel, followed by installing the four 6-32 3/8" Phillips pan head screws in the four holes on the front of the Evaporator Unit.

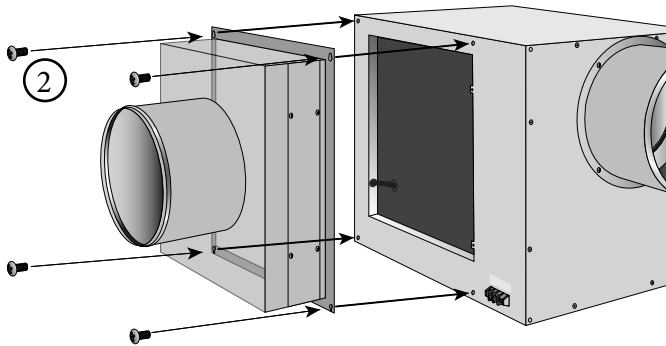

Secure the return air plenum by aligning the outer corner holes with the holes on the Evaporator Unit (Fan Coil Unit), followed by installing the four 6-32 3/8" Phillips pan head screws in the four holes on the front of the Evaporator Unit.

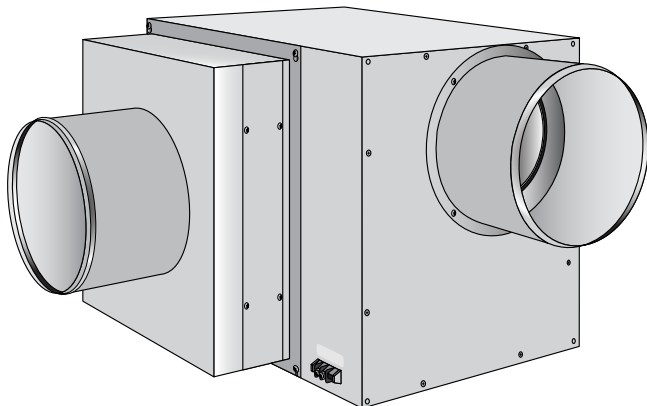

DUCTED PLATINUM SPLIT

Here are two options for ducting the Evaporator Unit (Fan Coil Unit). Option 1 is to duct the system through the wall. Option 2 is to duct the system through the ceiling. (All turns require an elbow.)

Option 1

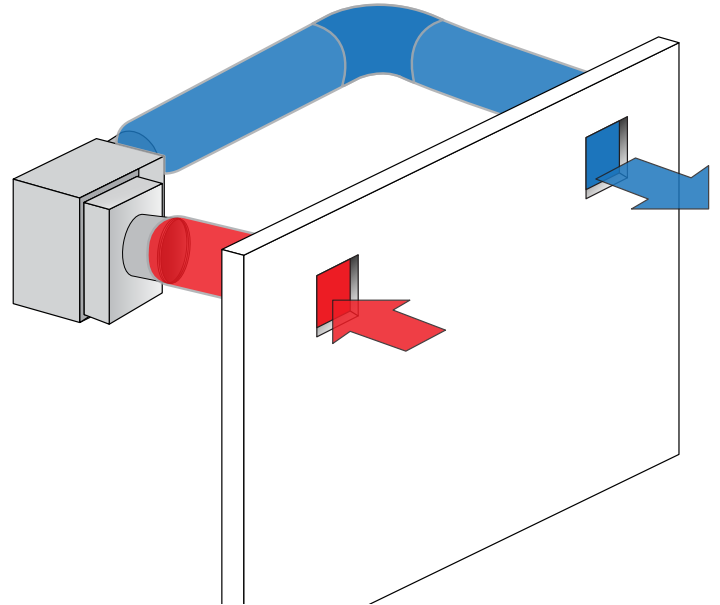

NOTE: The top of the registers needs to be installed with a minimum of six inches and a maximum of eighteen inches from the ceiling.

Option 2

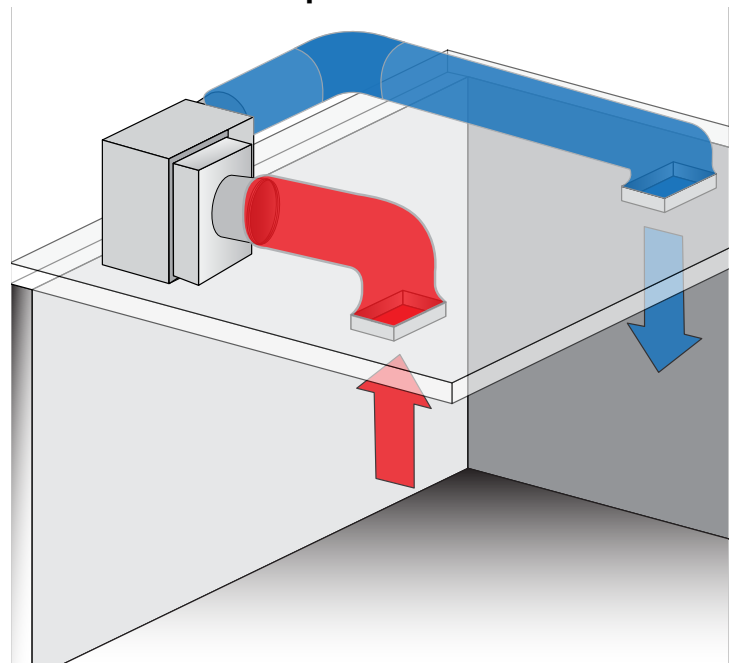

REMOTE KEYPAD: INSTALLATION AND CONFIGURATION

If you have a system with a remote keypad, please review this section for installation.

Note: 50 feet of communication line is included, the keypad can be installed up to 300 line feet away. Longer lengths of communication line can be ordered by calling 1-800-343-9463 ext. 751.

Run your communication line to the desired location, be sure not to have any harsh kinks in the lines route. Attach the connection wire as shown below, with the red wire in the upper connection slot and the black wire in the lower slot. It is also important to run your bottle probe line at this time,

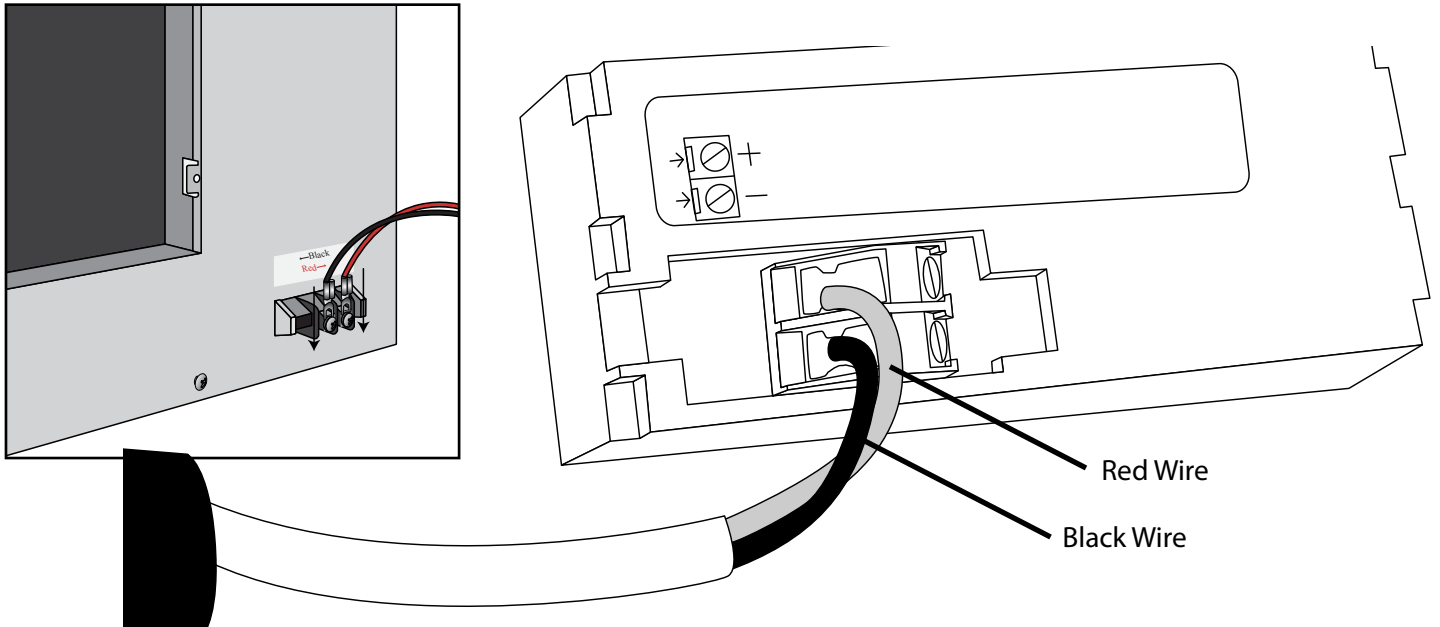

To install the remote keypad box, remove the rear mounting bracket and secure the bracket to the wall in the desired location. When running the communication line through a wall, be sure to run the line in the rear mount position and insert the supplied plug in the side hole on the box. Reattach the keypad box to the bracket.

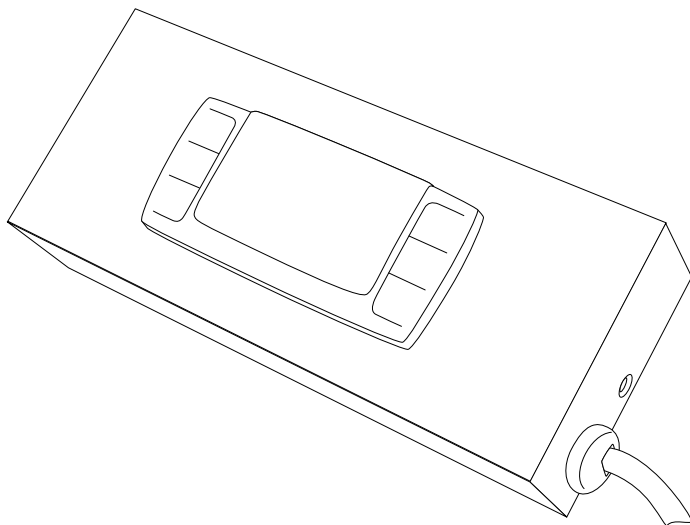

Connection wire in Side Mount configuration

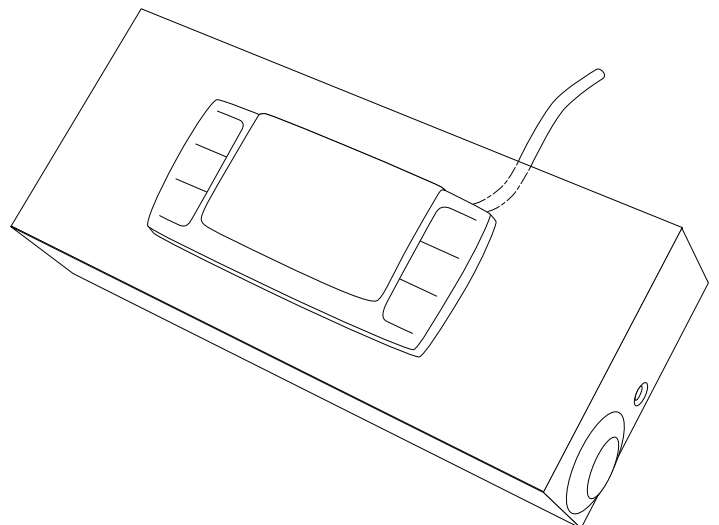

Connection wire in Rear Mount configuration

SYSTEM OPERATION

Initial Start-Up

When power is applied to the unit, the control will briefly display all symbols, and the Snow Flake symbol will be displayed (if unit is calling for cooling). There may be a brief delay prior to the evaporator fan turning on. When the evaporator fan is activated the Fan symbol will be displayed. The temperature control feature for the evaporator fan is a feature applicable to WhisperKOOL. This is the Advance Product Safety Technology (APST), which ensures that in the possible event of a cooling deficiency, the heat from the indoor fan will not raise the temperature of the wine cellar, which could otherwise have an adverse effect on the wine aging process.

Normal System Cycle

After the Bottle probe has reached the set point (all units are shipped with the set point of 55°F and a differential of 1°F). The FON function is an adjustable feature which allows the customer the convenience of managing humidity levels in their wine cellar. The FON Function is a feature that controls the evaporator fan operation once the set point has been reached. This function allows the evaporator fan to run and reintroduce humidity removed during the cooling process. All units come with this feature turned off. If low humidity is a problem an increase in this setting will raise the humidity level. The FON function is one of the many Customer Preference Selection features which allow the customer the ability to fine tune the controls.

Anti Short Cycle

The Anti Short Cycle ensures that the unit will remain off for a period of 5 minutes after the unit has reached the set point to allow the pressure in the refrigeration system to equalize prior to starting the compressor.

Anti Frost Cycle

The Anti Frost Cycle is a precautionary measure, as icing or frosting of the coil does not occur during normal operation. The system will go through a defrost cycle every 4 hours. During the defrost cycle, the indoor fan will provide air flow across the indoor coil, which will evaporate any frost accumulation.

Low Ambient Conditions

If the condensing unit is installed outside (which will allow the condenser to be exposed to low ambient temperatures), the condenser fan may cycle on and off. The purpose of the fan cycling is to maintain the system high side pressure, which will ensure an adequate refrigeration process. The fan cycling process is accomplished by way of a Johnson Control attached to

the condensing unit.

Bottle Probe Failure Protection

In the event that a Bottle probe should fail, the APST (Advance Product Safety Technology) will automatically transition the Refrigeration Compressor cycles to a pre-determined time series (based on detailed laboratory testing), which will ensure that the product is kept within the safe range.

Remote Key Pad (standard on ducted units)



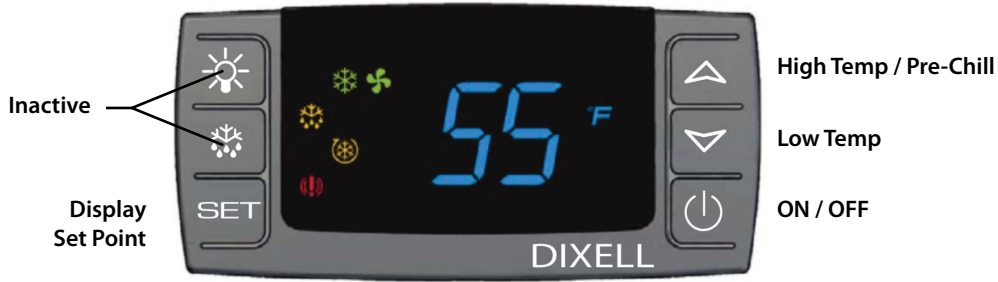

The remote keypad is designed to give the user the ability to monitor and change cellar conditions when the evaporating unit is placed in a remote location outside of the cellar.

REMOTE CONTROLLER FUNCTIONS

If your unit has a remote keypad then you will have the Remote Controller.



TEMPERATURE

Button	Normal Functions
<p>ON/OFF</p> 	<ul style="list-style-type: none"> The ON/OFF button allows the customer the convenience of turning the refrigeration system ON or OFF, from the control panel. This feature does not disconnect power from the unit. In order for the power to be shut off from the unit, the power cord must be unplugged from the wall receptacle. Press the ON/OFF button once for button application.
<p>Up and Down Arrows</p>  	<ul style="list-style-type: none"> Use these buttons to scroll up or down the CPSM (Customer Preference Selection Mode) menu. Displays the Highest and Lowest temperature sensed by the Bottle Probe. This feature allows the customer instant access to the recorded data applicable to the Bottle Probe Temperatures, it can be easily reset to reflect current temperatures. <ol style="list-style-type: none"> Press the "UP" arrow, or the "Down" arrow once, and the Highest or Lowest Temperature (Hi/Lo) sensed by the Bottle Probe, will be displayed. To reset the Hi/Lo, press and hold the "Set" button when the Hi/Lo value is displayed on the Digital Display, continue to hold the "Set" button until "rst" appears on the digital display and then blinks. This will erase the past recorded "Temperature Data History" and start recording, from the current time and temperature, forward. Temperatures displayed would reflect Bottle Probe Temperatures from that point in time, and beyond. The Hi/Lo feature should be reset at initial "Start-Up" and after the Cellar or Cabinet has obtained normal operating temperatures, which is generally 55°F.
<p>Cellar PreChill (CPC)</p>  	<p>The CPC Feature is activated by pressing the Up button for 3-5 seconds, and the CPC logo will be displayed on the digital display. The CPC feature can be terminated by pressing the Up button for 3-5 seconds, or the feature will self terminate after 6 hrs.</p> <ol style="list-style-type: none"> The (CPC) Feature may be used to Pre-Chill the Cellar prior to loading it with Warm Product. The feature will shift the Set Point down to a lower setting of 52°F, for the next 6 hours. After the 6 hour time period, the Set Point will automatically return to the original Set Point. The CPC feature can be conveniently adjusted to the customer's specific needs, by accessing the "Customer Preference Select Mode" (CPSM). See Customer Preference Select Mode Instructions.

SET	<p>Set</p> <ol style="list-style-type: none"> 1. Press the "Set" button once and it will display the Set Point. After approximately 5 seconds, the display will return to normal operation and display the Bottle Probe temperature. 2. Press the "Set" button once and it will display the Set Point. Press the up and down arrows to change the set point. Press the Set button again and the numbers will blink, confirming the change in Set Point. 3. Press and hold the "Set" button during the display of the Hi/Low "Temperature Data History" (hold button unit "rst" blinks on display), and it will erase the past recorded data file and start recording, from the current time and temperature. 4. Press the "Set" and the "Down Arrow" buttons simultaneously, for 3-5 seconds, and you will access the "Customer Preference Selection Mode" (CPSM). The CPSM allows the customer to "Fine Tune" the Control Operating System to their applicable choice.
	<p>Alarm</p> <p>The Alarm symbol is shown when the unit encounters an issue that needs attention, the displayed alarm codes are explained below.</p>

Alarm Codes

Message	Cause	Solution
"P1"	Bottle Probe is Unplugged	Attach Bottle Probe to Unit
	Faulty Bottle Probe Connection	1. Check Bottle Probe attachment at circular connector 2. Check Bottle Probe connection at green terminal block on back of controller
	Defective Bottle Probe	Replace the Bottle Probe
"P2"	Faulty Evaporator Probe Connection	Check Evaporator Probe connection at green terminal block on back of controller
	Defective Evaporator Probe	Replace the Evaporator Probe
"HA"	Defective Bottle Probe	Replace the Bottle Probe
"LA"	The Bottle Probe is sensing a temperature of 4° below the set point	Allow the room to warm up which will increase the temperature of the wine
	Defective Bottle Probe	Replace the Bottle Probe
"POF"	The keypad is locked	Hold "Up" and "Down" buttons for 3 to 5 seconds to disable, "PON" should appear

<p>CPSM Mode</p>	<p>Press the "Set" and the "Down Arrow" buttons simultaneously, for 3-5 seconds, and you will access the "Customer Preference Selection Mode" (CPSM). The CPSM allows the customer to "Fine Tune" the Control Operating System to their applicable choice.</p> <p>The following CPSM options are available for adjustment:</p> <p>Fon – Humidity Management Enhancement: This parameter is normally set at 0, which should provide adequate relative humidity for the cellar.</p> <ul style="list-style-type: none"> • An increase in this parameter will increase the Humidity Enhancement (%RH), and a decrease in the parameter will decrease Humidity Enhancement (%RH). • Adjustments should be made in increments of 5, with a maximum of 15, and a minimum of 0. • After any adjustment to Humidity Enhancement, you should wait a minimum of three days before making any additional adjustments. This will allow the cellar sufficient time to acclimate to the new setting. <p>Fof - Humidity Management Enhancement: This parameter is normally set at 15. This parameter should not be adjusted, as it simply provides an OFF cycle time for the fan, during the compressor OFF cycle. However, the parameter is located within the CPSM as a convenience to the customer, should it need to be adjusted. CCT - Cellar Pre-Chill Duration: This parameter is set to 6 hours, but can be changed between 0-23.5 hours.</p> <p>Con/Cof – Compressor On time (Con) and Off time (Cof) with a Probe 1 failure/Alarm. These parameters are set at Con 40 min/Cof 10 min. In the event that there is a Probe 1 failure/ Alarm, the compressor/refrigeration system automatically starts a predetermined ON/OFF cycle, which is controlled by the Con and the Cof parameters. The customer can adjust these parameters to maintain the desired Bottle temperature.</p>
-------------------------	---

TROUBLESHOOTING GUIDE

Unit has ice forming on the Evaporator Unit (Fan Coil Unit)

Possible Cause	Solution
Evaporator filter or coil is dirty.	Remove the filter and wash, then clean the coil with a vacuum. If coil is very dirty, use a spray bottle with a small amount of liquid dish washing detergent or coil cleaner. Spray coil, let set for 5 min, then flush with fresh water.
There is something blocking the supply and or return air	Remove blockage
The evaporator fan is not turning on.	Call a service tech to troubleshoot
The Evaporator Unit (Fan Coil Unit) has not gone through its anti-frost sequence, yet.	Check for ice in the depth of the coil. Melt with blow drier until coil is warm to the touch. Soak up water with a towel.
If Evaporator Unit (Fan Coil Unit) continues to ice.	Observe ice formation pattern. If only part way up the coil face, the system could be low on refrigerant. If all the way up, the coil may be dirty or airflow is blocked.

Unit does not run/power up

Possible Cause	Solution
Evaporator Unit (Fan Coil Unit) is not plugged in	Make sure the unit is plugged into an outlet
Power switch not on	Turn unit on by pressing the power button on the control
Line voltage is incorrect rating for the system	Check line voltage to make sure there is 110v/120v
Bottle at set point	Lower set point
Thermostat not calling for cooling	Lower set point
Faulty thermostat or wiring	Call Customer Service at 1-800-343-9463

Cellar Temperature is too Warm

Possible Cause	Solution
The system is undersized for the cellar.	Order correct size system
There is something blocking the supply and/or return air, on the Evaporator Unit (Fan Coil Unit)	Remove air flow obstruction
Evaporator Unit (Fan Coil Unit) is mounted too low in the cellar	Re-Locate unit so the distance from the ceiling and top of the unit is no more than 18"
One or more of the fans are not turning on.	Please contact the installing technician to troubleshoot.
Compressor is not turning on.	Please contact the installing technician to troubleshoot.
Compressor keeps cycling on overload	Make sure all fans are working and there are no airflow obstruction.
Poor seal around door or other areas requiring a seal (around the unit, wall joints, etc)	Make sure there are no air gaps around the door. If door seal is damaged, replace it.
Controller set too high	Lower the set point.
Evaporator coil is frosted or iced up	Observe ice formation pattern. If only part way up the coil face, Evaporator Unit (Fan Coil Unit) could be low on refrigerant. If so, contact your installing technician to assist with troubleshooting.

System Runs Constantly

Possible Cause	Solution
Leaky door seal or poorly insulated cellar.	Fix leaky door seal and insulate cellar in accordance with this manual. (Page 9)

TROUBLESHOOTING GUIDE

Unit leaks water	
Possible Cause	Solution
Evaporator Unit (Fan Coil Unit) is not level	Evaporator Unit (Fan Coil Unit) should be level on the wall to prevent leaking.
Drain line clogged or kinked	Check drain line to make sure water can flow freely.
Drain is clogged preventing water from escaping	Disconnect drain and clear out, open access door and check drain for blockage
Drain line does not have a downward slope	Fix Drain line so there is a downward slope from the unit to the drain.
Coil is iced causing drain pan ice and water overflowing	Melt ice with blow drier. Soak up with a towel
Unit runs but does not cool	
Possible Cause	Solution
Lack of air flow	Make sure fan is unobstructed; Make sure the evaporator filter, evaporator coil, and condenser coil are clean and free of debris.
System undersized	Contact Customer Service at 800-343-9463
Compressor is overheating	Shut system off for 1 hour to allow compressor to cool. Turn back on and check for cooler air flow out. If compressor runs, check for and clean condenser coil as possible cause of compressor overheating. If problem repeats, contact you installing technician to assist with troubleshooting.
Evaporator fan runs but compressor does not	
Possible Cause	Solution
Running an Anti-Frost Cycle	1) If the system is maintaining the correct cellar temperature and there is a dripping snowflake symbol illuminated on the control, the system is going through an anti frost cycle. No action Required. 2) If the system is not maintaining the correct cellar temperature this may be caused by a dirty evaporator filter or coil. 3) Call installing technician to troubleshoot as the system may be low on charge or an adjustment to the TXV.
Compressor and/or starting components faulty	Please contact the installing technician to troubleshoot.
System may be performing the WHM function	Allow cooling system to revert back to cooling mode.
Compressor may have overheated.	Shut system off for 1 hour to allow compressor to cool. Turn back on and check for cooler air flow out. If compressor runs, check for and clean condenser coil as possible cause of compressor overheating. If problem repeats, contact you installing technician to assist with troubleshooting.
Compressor runs but evaporator fan does not	
Possible Cause	Solution
Faulty fan motor	Please contact the installing technician to troubleshoot.
Faulty Controller	Please contact the installing technician to troubleshoot.
Compressor short cycles	
Possible Cause	Solution
Evaporator Unit (Fan Coil Unit) blows on bottle probe	Move bottle probe to a more central location.
System low on refrigerant charge	Please contact the installing technician to troubleshoot.
Compressor and /or starting components faulty	Please contact the installing technician to troubleshoot.
Humidity in cellar too low	
Possible Cause	Solution
Not enough moisture	Raise the Fon setting to increase the humidity level

TECHNICAL ASSISTANCE

WhisperKOOL Customer Service is available Monday through Friday from 6:00 a.m. to 4:00 p.m. Pacific Time.

The customer service representative will be able to assist you with your questions and warranty information more effectively if you provide them with the following:

- The model and serial number of your WhisperKOOL systems.
- Location of unit and installation details, such as ventilation, ducting, construction of your wine cellar, and room size. Photos of the cellar and installation location may be needed.

Contact WhisperKOOL Customer Service

1738 E. Alpine Ave
Stockton, CA 95205
www.WhisperKOOL.com
Email: support@whisperkool.com
Phone: (209) 466-9463
US Toll Free 1(800) 343-9463
Fax (209) 466-4606

ACCESSORIES FOR COOLING UNITS

WhisperKOOL offers accessories to enhance and customize your wine cooling unit.

Condensate Pump Kit

The condensate pump kit is designed as an automatic condensate removal pump for water dripping out of our Evaporator Unit's (Fan Coil Unit's) drain line. The pump is controlled by a float/switch mechanism that turns the pump on when approximately 2-1/4" of water collects in the tank, and automatically switches off when the tank drains to approximately 1-1/4". The condensate pump kit allows the excess condensate to be pumped up to 20ft away from the unit.

Accessories can be purchased at www.whisperkool.com

NOTES

*Whisper***KOOL**[™]

WhisperKOOL
1738 E. Alpine Ave
Stockton, CA 95205
1(800) 343-9463
www.whisperkool.com